



# HP Latex Plus Cutter Series

User Guide

Edition 2

© Copyright 2021 HP Development Company, L.P.

#### **Legal notices**

The information contained herein is subject to change without notice.

The only warranties for HP products and services are set forth in the express warranty statements accompanying such products and services. Nothing herein should be construed as constituting an additional warranty. HP shall not be liable for technical or editorial errors or omissions contained herein.

#### **Trademarks**

Microsoft® and Windows® are U.S. registered trademarks of Microsoft Corporation.

---

# Table of contents

|   |           |
|---|-----------|
| <b>1 Introduction</b>                         | <b>1</b>  |
| Welcome to your cutter                        | 2         |
| Cutter models                                 | 2         |
| Documentation                                 | 2         |
| Safety precautions                            | 3         |
| Main cutter components                        | 6         |
| Turn the cutter on and off                    | 8         |
| Connect the cutter to a computer              | 8         |
| Front panel                                   | 9         |
| <b>2 Useful links</b>                         | <b>10</b> |
| When you need help                            | 10        |
| <b>3 Load the substrate</b>                   | <b>12</b> |
| Position the pinch rollers                    | 16        |
| Calibrate the substrate                       | 17        |
| Adjust cutting parameters                     | 19        |
| Perform length calibration                    | 21        |
| Media Sensor calibration (Media Sensor Setup) | 22        |
| Change user                                   | 25        |
| <b>4 Cutting workflow</b>                     | <b>27</b> |
| Job types                                     | 27        |
| Cut types                                     | 27        |
| Job editing and management (RIP)              | 30        |
| Automate cutting tasks                        | 33        |
| Processing long jobs                          | 34        |
| OPOS origin                                   | 35        |
| Read the HP barcode                           | 36        |
| Calibrate the OPOS                            | 37        |
| Change the origin                             | 38        |
| Extended load                                 | 38        |

|  |           |
|--|-----------|
| <b>5 Detailed operation of the cutter .....</b>  | <b>40</b> |
| Introduction .....   | 40        |
| Home screen .....  | 42        |
| Main menu .....  | 42        |
| Knife pressure .....   | 42        |
| Knife offset .....   | 43        |
| FlexCut .....  | 43        |
| Tool .....   | 44        |
| Actions .....  | 44        |
| Settings .....   | 45        |
| Calibrations .....   | 47        |
| Configuration .....  | 47        |
| <br>   |           |
| <b>6 Maintenance .....</b>   | <b>50</b> |
| Clean cutter surfaces .....  | 50        |
| Clean the drive system .....   | 50        |
| Clean the substrate sensor .....   | 51        |
| Clean the Y-guide rail .....   | 51        |
| Replace the knife .....  | 52        |
| Change the fuse .....  | 54        |
| Update the firmware .....  | 55        |
| <br>   |           |
| <b>7 Troubleshooting .....</b>   | <b>56</b> |
| Cutting quality is not satisfactory .....  | 56        |
| Substrate is drifting and you have tracking issues .....   | 56        |
| Substrate jams .....   | 57        |
| Cutter cannot detect HP barcode or registration marks .....  | 57        |
| Cutter can't detect that media is loaded or loading doesn't start after lowering the pinchwheels ..... | 57        |
| <br>   |           |
| <b>8 Accessories .....</b>   | <b>62</b> |
| Order accessories .....  | 62        |
| <br>   |           |
| <b>9 Specifications .....</b>  | <b>63</b> |
| Cutter dimensions .....  | 63        |
| Shipping dimensions .....  | 63        |
| Substrate dimensions .....   | 63        |
| Performance .....  | 64        |
| Firmware .....   | 65        |
| Environment .....  | 65        |
| Electrical .....   | 65        |
| Acoustic .....   | 65        |
| <br>   |           |
| <b>Index .....</b>   | <b>66</b> |

---

# 1 Introduction

- [Welcome to your cutter](#)
- [Cutter models](#)
- [Documentation](#)
- [Safety precautions](#)
- [Main cutter components](#)
- [Turn the cutter on and off](#)
- [Connect the cutter to a computer](#)
- [Front panel](#)

## Welcome to your cutter

Your cutter is a drag-knife contour cutter designed to cut flexible substrates accurately. Some major features of the cutter are shown below:

- Optical Positioning System (OPOS) and HP Barcode System for precise and unattended cutting
- Different cutting modes, with the ability to cut completely through some substrates
- High-speed cutting head, for reliable and effortless vinyl cutting
- Touchscreen to modify settings easily
- Intelligent substrate system to keep substrates on track, even when cutting at top speed
- Ethernet (LAN) and USB connectivity
- Substrate basket included

To send print jobs to your printer, you will need Raster Image Processor (RIP) software, which should be run on a separate computer. RIP software is available from various different companies. Included in the box is a license for the HP FlexiPrint and Cut RIP, supporting Print and Cut and Direct Cut workflows.

## Cutter models

| HP 54 Basic Plus Cutter, HP Latex 54 Plus Cutter, and HP Latex 64 Plus Cutter |  |
|---|--|
| Supplied with the cutter  | HP standard blades (2)<br>HP cut-off knife<br>HP 3-in substrate flanges<br>HP FlexiPrint and Cut RIP license |
| Optional accessories  | HP Latex Specialty Blade Kit   |
| Consumables   | HP Latex Standard Blade Kit  |

## Documentation

The following documents can be downloaded from <http://www.hp.com/go/latex115plusprintandcutter/manuals>, <http://www.hp.com/go/latex315plusprintandcutter/manuals>, or <http://www.hp.com/go/latex335plusprintandcutter/manuals>:

- Introductory information
- Site preparation guide
- Assembly instructions
- User guide
- Legal information
- Limited warranty

# Safety precautions

Before using your cutter, read the following safety precautions to make sure you use the equipment safely.

You are expected to have the appropriate technical training and experience necessary to be aware of hazards to which you may be exposed in performing a task, and take appropriate measures to minimize the risks to yourself and to other people.

This equipment is not suitable for use in locations where children are likely to be present.

## General safety guidelines

- There are no operator-serviceable parts inside the cutter except those covered by HP's Customer Self Repair program (see <http://www.hp.com/go/selfrepair/>). Refer servicing of other parts to qualified service personnel.
- Turn off the cutter and call your service representative in any of the following cases:
  - The power cord or plug is damaged.
  - The cutter has been damaged by an impact.
  - There is any mechanical or enclosure damage.
  - Liquid has entered the cutter.
  - There is smoke or an unusual smell coming from the cutter.
  - The cutter has been dropped.
  - The cutter is not operating normally.
- Turn off the cutter in either of the following cases:
  - During a thunderstorm
  - During a power failure
- Take special care with zones marked with warning labels.
- Ventilation measures for your location, whether office, copy room, or printer room, should meet local environmental health and safety (EHS) guidelines and regulations.

## Electrical shock hazard

---

 **WARNING!** The internal circuits of the built-in power supplies operate at hazardous voltages capable of causing death or serious personal injury.

---

The cutter uses one power cord. Unplug the power cord before servicing the cutter.

To avoid the risk of electric shock:

- The cutter must be connected to earthed mains outlets only.
- Do not remove or open any other closed system covers or plugs.
- Do not insert objects through slots in the cutter.
- Take care not trip over the cables when walking behind the cutter.
- Insert the power cord securely and completely into the wall socket and cutter inlet.
- Never handle the power cord with wet hands.

## Fire hazard

To avoid the risk of fire, take the following precautions:

- The customer is responsible for meeting the cutter's requirements and the Electrical Code requirements according to the local jurisdiction of the country where the equipment is installed. Use the power supply voltage specified on the nameplate.
- Connect the power cords to a line protected by a branch circuit breaker according to the information detailed in the site preparation guide. Do not use a power strip (relocatable power tap) to connect the power cord.
- Use only the power cord supplied by HP with the cutter. Do not use a damaged power cord. Do not use the power cord with other products.
- Do not insert objects through slots in the cutter.
- Take care not to spill liquid on the cutter. After cleaning, make sure all components are dry before using the cutter again.
- Do not use aerosol products that contain flammable gases inside or around the cutter. Do not operate the cutter in an explosive atmosphere.
- Do not block or cover the openings of the cutter.

## Mechanical hazard

The cutter has moving parts that could cause injury. To avoid personal injury, take the following precautions when working close to the cutter:

- Keep your clothing and all parts of your body away from the cutter's moving parts.
- Avoid wearing necklaces, bracelets, and other hanging objects.
- If your hair is long, try to secure it so that it will not fall into the cutter.
- Take care that sleeves or gloves do not get caught in the cutter's moving parts.
- Do not touch gears or moving rolls during printing.
- Do not operate the cutter with covers bypassed.

## Light radiation hazard

Light radiation is emitted from the LED status indicators and front panel. This illumination is in compliance with the requirements of the exempt group of IEC 62471:2006, *Photobiological safety of lamps and lamp systems*. However, you are recommended not to look directly at the LEDs while they are on. Do not modify the module.

## Heavy substrate hazard



Special care must be taken to avoid personal injury when handling heavy substrates:

- Handling heavy substrate rolls may require more than one person. Care must be taken to avoid back strain and/or injury.
- Consider using a forklift, pallet truck, or other handling equipment.
- When handling heavy substrate rolls, wear personal protective equipment including boots and gloves.





## Warnings and cautions

The following symbols are used in this manual to ensure the proper use of the cutter and to prevent the cutter from being damaged. Follow the instructions marked with these symbols.

-  **WARNING!** Failure to follow the guidelines marked with this symbol could result in serious personal injury or death.
-  **CAUTION:** Failure to follow the guidelines marked with this symbol could result in minor personal injury or damage to the cutter.

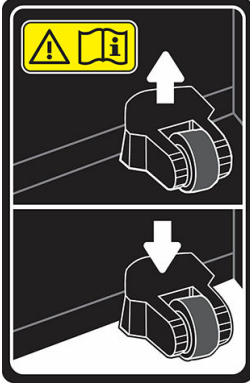
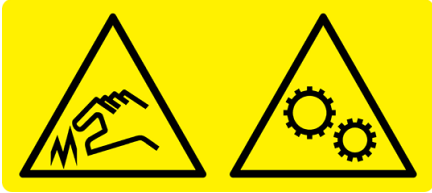
## Warning labels

| Label  | Explanation  |
|--|--|
|  <p>Risk of electric shock. Do not open.<br/>Double pole / neutral fusing.<br/>For continued protection against risk of fire,<br/>replace only with same type and rating of fuse.</p> <p>Risque de choc électrique. Ne pas ouvrir.<br/>Double pôle / fusible sur le neutre.<br/>Pour ne pas compromettre la protection<br/>contre les risques d'incendie, remplacer<br/>par un fusible de même type et de mêmes<br/>caractéristiques nominales.</p> | <p>Fuse caution label. For continued protection against risk of fire, replace the fuse only with one of the same rating.</p> <p>Double pole/Neutral fusing</p> <p>This label is located near the power inlet, at the rear.</p> |
|    | <p>Caution: Always leave the pinch rollers in the upper positions when the cutter is not in use.</p> <p>This label is located on the plate at the right.</p>   |
|   | <p>Hazardous moving part. Keep your fingers and other body parts away from this area.</p> <p>This label is located on the cutting head.</p>  |

-  **NOTE:** The final label position and size may vary slightly, but should always be visible and close to the potential risk area.

## Main cutter components

The following views of the cutter illustrate its main components.

### Front view

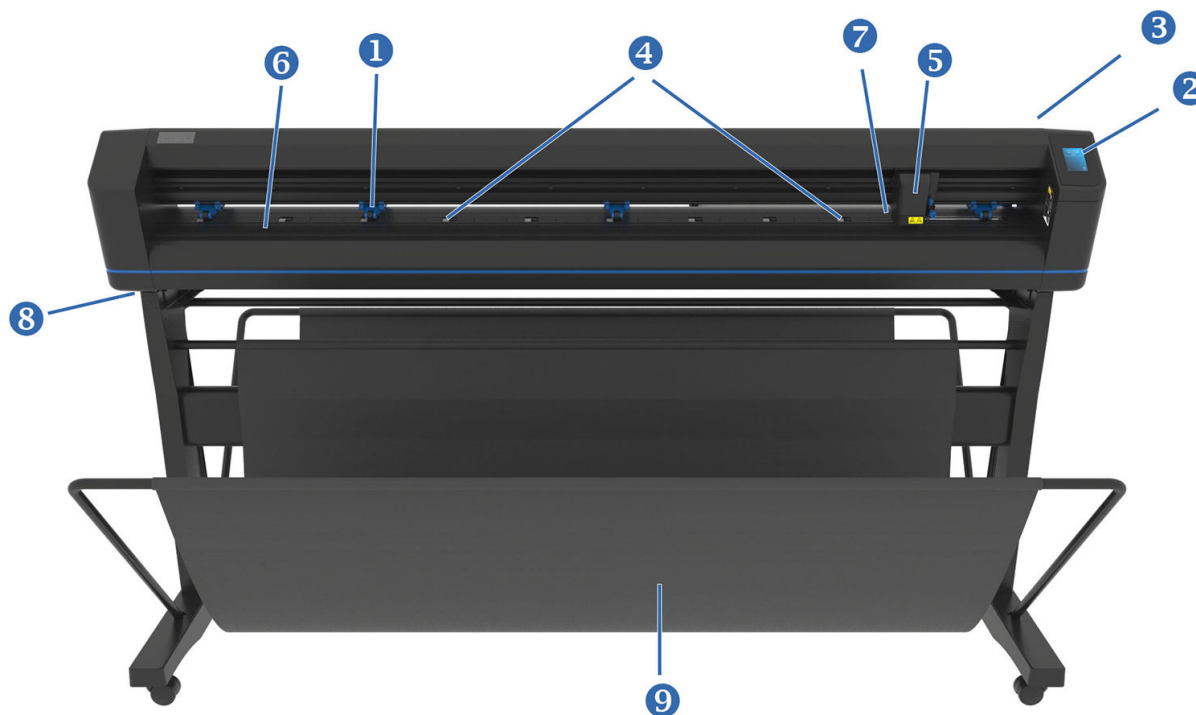

1. **Pinch rollers:** The pinch rollers clamp the substrate to the drive system to ensure accurate tracking. The two central rollers ensure that a wide substrate stays flat in the middle; they can be enabled or disabled.
2. **Front panel:** All cutter activity can be initiated from this touchscreen. It displays information about the cutter's current status and/or actions that need to be taken.
3. **Pinch roller lever:** This lever is used to raise and lower the pinch rollers for substrate loading.
4. **Substrate drive sleeves:** These sleeves move the substrate only when the pinch rollers are in the down position. The larger the model, the more small sleeves.
5. **Tool carriage:** The tool carriage is the mount for the knife holder, pen, or pouncing tool. It also holds the Optical POSitioning sensor (OPOS).
6. **Cutting strip:** A self-healing orange strip helps avoid any damage to the knife tip when no substrate has been loaded. Since cutting is done on the cutting strip, it is essential that the strip remains intact.
7. **Substrate sensor:** This sensor, located behind the right sleeve, is used to detect the end of the loaded substrate.
8. **Screws to secure the cutter base:** Make sure all screws are secured at each side before the cutter is used.
9. **Substrate basket.**

## Rear view

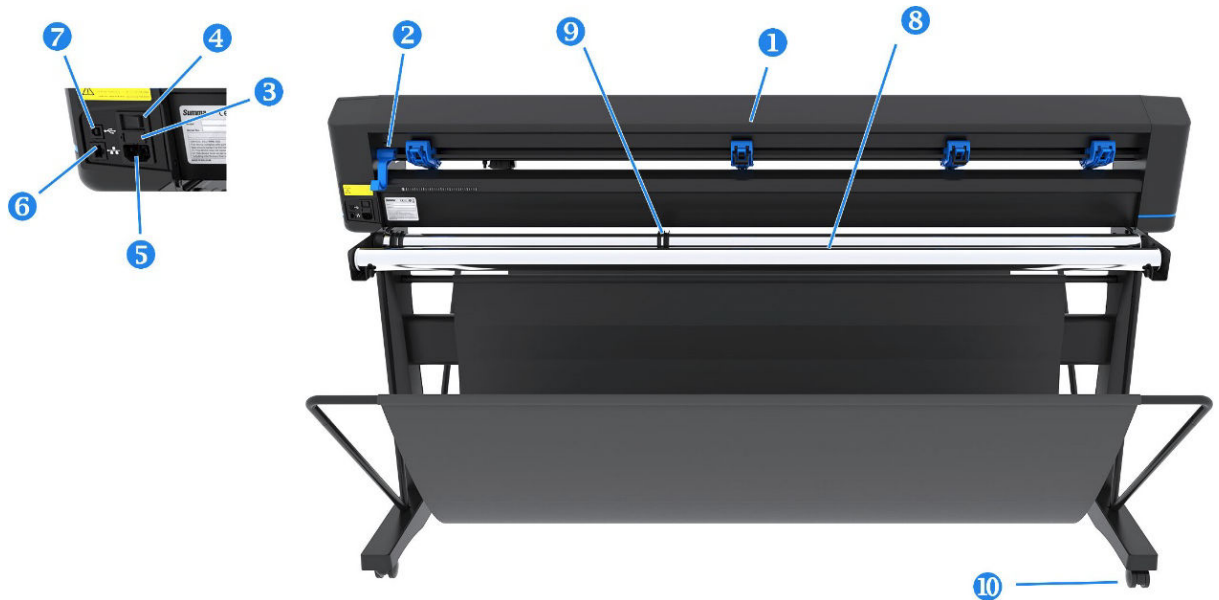

1. **Pinch rollers:** The pinch rollers clamp the substrate to the drive system to ensure accurate tracking. The two central rollers ensure that a wide substrate stays flat in the middle; they can be enabled or disabled.
2. **Pinch roller lever:** This lever is used to raise and lower the pinch rollers for substrate loading.
3. **Fuse box:** The fuse is located at the right-hand side of the power entry module. See [Electrical on page 65](#) for details of the fuse.

**⚠ CAUTION:** For continued protection against risk of fire, replace only with the same type and rating of fuse.

4. **Power on/off switch:** This rocker switch, situated in the middle of the power entry module, turns the cutter on and off. To turn it on, press the 'I' side of the rocker switch. To turn it off, press the 'O' side of the rocker switch.
5. **AC power socket:** The socket is located at the left-hand side of the power entry module. The power-up procedure is explained in [Turn the cutter on and off on page 8](#). Always use the power cord that was delivered with your cutter.
6. **USB port:** This interface is based on the standards specified in Universal Serial Bus Specifications Revision 1.1. It allows a high-speed bi-directional communication between the host computer and the cutter.
7. **Ethernet port RJ45:** For connecting the cutter to your local-area network.
8. **Substrate-support rollers:** Rotating support rollers for the substrate roll.
9. **Substrate-roll guide bushes:** The two flange guides serve to keep the substrate roll in place when substrate is pulled from the roll.
10. **Casters:** The casters on the stand are equipped with locking brakes. Once the cutter has been moved to its new location, press the brakes with your foot to lock the casters.

## Turn the cutter on and off

The power switch is located on the cutter's rear panel.

**⚠ CAUTION:** Before connecting the power cord, ensure that the power switch is turned off (to the position marked '0').

To turn on the cutter, turn the power switch to the position marked 'I'.

When the cutter is turned on, the touchscreen activates and the cutter initializes itself. If substrate is loaded, the cutter checks its size.

## Connect the cutter to a computer

The cutter has bidirectional USB and LAN ports for connection to a computer. If both ports are connected, the port that receives data first remains active, and the other port is deactivated.

### LAN connection (recommended)

Connect the LAN cable at the back of the cutter and connect the other end to the network.

By default, the cutter has DHCP activated, so the server automatically assigns an IP address to the cutter. The assigned address can be viewed in the front panel.

To set a static IP address, go to the front panel and tap  , then **Configuration > Ethernet > DHCP > Off**, and confirm. Then, in the same menu, manually enter the IPv4 address and subnet (check with the network administrator if necessary). Restart the cutter to apply the new settings.

### USB connection

The USB cable should be no longer than 5 m (16 ft).

#### Procedure for Microsoft Windows

1. Turn off the cutter.
2. Ensure that you have administrative rights on the computer, and that User Account Control is deactivated or set to its lowest level.
3. Click **Install USB driver**, and wait for the driver to install. The HP FlexiPrint and Cut RIP is also installed automatically.
4. Connect one end of the USB cable to a USB port on the computer. This end of the cable should have a 4-pin USB series A connector.
5. Connect the other end of the cable to the USB port at the back of the cutter. This end of the cable should have a 4-pin USB series B connector.
6. Turn on the cutter (see [Turn the cutter on and off on page 8](#)) and return to the computer.

To connect more than one cutter to the same computer, see [USB port on page 48](#).

#### Procedure for Apple Mac OS X

1. Turn off the cutter.
2. Connect one end of the USB cable to a USB port on the computer. This end of the cable should have a 4-pin USB series A connector.

3. Connect the other end of the cable to the USB port at the back of the cutter. This end of the cable should have a 4-pin USB series B connector.
4. Turn on the cutter (see [Turn the cutter on and off on page 8](#)).

Most cutting software for Mac OS X can control the cutter without the installation of a driver.

## Front panel

The front panel provides detailed cutter status information and gives you flexible and powerful control of the cutter's configuration.

All controls on the front panel's touchscreen are easily formatted to allow quick access to the most common cutter settings.

Next to the status messages or menu options, you can tap button symbols to change menu items or parameter values.



After a certain amount of time sitting idle, the screensaver appears. You can return to the normal display by touching the screen.

If applicable, tips or advice may be shown instead of the screensaver. For example, when the cutter is not busy and the pinch rollers are down, a warning message appears.

**⚠ WARNING!** Whenever you tap a control on the front panel, it may initiate an internal test or movement of the head or substrate. Keep fingers and other body parts away from the cutting area, where there are hazardous moving parts.

### Control buttons



The Settings button gives access to the main menu. When you tap this button, the cutter goes offline and suspends all operations in progress. The main menu contains all parameter settings and submenus, and access to tests and calibration routines. The chosen tool will influence the displayed settings.



When you tap the Origin button, the front panel displays the current origin and allows you to change it by using the arrow keys (which appear once the button is pressed).



Online and pause are two important concepts when using the cutter. When online, the cutter can be controlled by the host computer, which means that the cutter will execute cutting or plotting instructions issued by the host computer's application software. Whenever you tap any other button on the cutter, the cutter pauses and can no longer be controlled by the host computer. However, if the computer was busy sending cutting data to the cutter it will be able to do so until the buffer of the cutter is full.



Tap this button to display the firmware version and serial number of the cutter.



Tap this button to stop the current job.

---

## 2 Useful links

Visit the HP Latex Knowledge Center at <http://www.hp.com/communities/HPLatex>, where you can find detailed information about our HP Latex products and applications, and use the forum to discuss anything related to the business.

Product documentation: <http://www.hp.com/go/latex115plusprintandcutter/manuals>, <http://www.hp.com/go/latex315plusprintandcutter/manuals>, or <http://www.hp.com/go/latex335plusprintandcutter/manuals>.

Videos about how to use the cutter: <http://www.hp.com/supportvideos/> or <http://www.youtube.com/HPSupportAdvanced>.

For a complete training program, see <https://hpllatexknowledgecenter.com/blog/hp-latex-print-and-cut-plus-training>.

Information about software RIPs, applications, solutions, inks, and substrates: <http://www.hp.com/go/latex300/solutions/> and <http://www.hp.com/go/latex115/solutions/>.

HP Support: <http://www.hp.com/go/latex115plusprintandcutter/support>, <http://www.hp.com/go/latex315plusprintandcutter/support>, or <http://www.hp.com/go/latex335plusprintandcutter/support>.

## When you need help

In most countries, support is provided by HP support partners (usually the company that sold you the product). If this is not the case in your country, contact HP Support on the Web as shown above.

Help is also available to you by telephone. What to do before you call:

- Review the relevant parts of this guide.
- Review your software documentation, if relevant.
- Please have the following information available:
  - The product you are using: the product number and serial number.



**NOTE:** These numbers are on a label at the rear of the cutter.

---

- If there is an error code on the front panel, note it down.
- The RIP you are using, and its version number.
- If relevant, the substrate you are using.

## Telephone number

Your HP Support telephone number is available on the Web: see [http://welcome.hp.com/country/us/en/wwwcontact\\_us.html](http://welcome.hp.com/country/us/en/wwwcontact_us.html).

## Customer Self Repair

HP's Customer Self Repair program offers our customers the fastest service under either warranty or contract. It enables HP to ship replacement parts directly to you (the end user) so that you can replace them. Using this program, you can replace parts at your own convenience.

### Convenient, easy to use

- An HP Support Specialist will diagnose and assess whether a replacement part is required to address a defective hardware component.
- Replacement parts are express-shipped; most in-stock parts are shipped the very same day you contact HP.
- Available for most HP products currently under warranty or contract.
- Available in most countries.

For more information about Customer Self Repair, see <http://www.hp.com/go/selfrepair/>.

## 3 Load the substrate

 **IMPORTANT:** You are strongly recommended to load the substrate before preparing the job on the computer.

The loading process is the same, whether the job is a print-and-cut job or just a cut job.

You can load both rolls and sheets of substrate into the cutter. Sheets can be loaded from the front or the rear; rolls must be loaded from the rear.

 **NOTE:** There are different cutter models. Your cutter may not correspond exactly to the model shown in the illustrations.

### Load a roll

1. Raise the pinch rollers with the pinch-roller lever arm, which is located at the right-hand side of the cutter, next to the front panel.

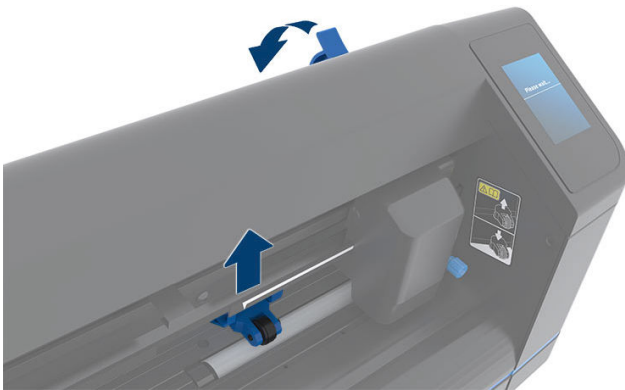

2. Loosen the knobs on the two substrate flanges. The following illustration shows a loosened flange (1) and a tightened flange (2).

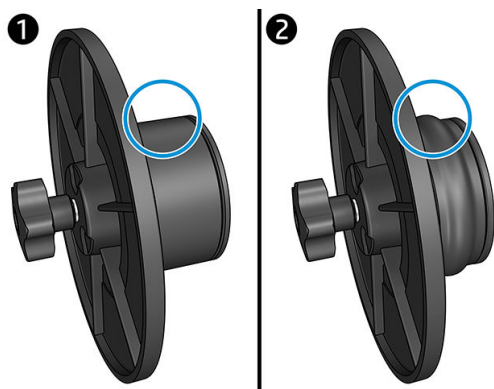

3. Insert a loosened flange into one end of the substrate roll and tighten the knob. Verify that the flange is secure. Then do the same at the other side of the roll.



- Place the flange-equipped roll on the substrate supply rollers. Set the flanges inside the groove of the flange guide. The flange guides can be moved laterally on the roller.

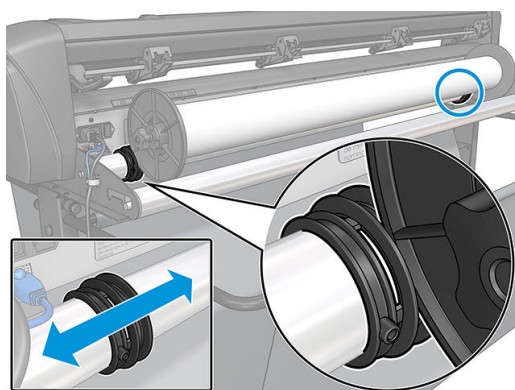

If the flanges are not used (this is not recommended, because then tracking is not guaranteed), then make sure that the roll is situated between the two flange guides.

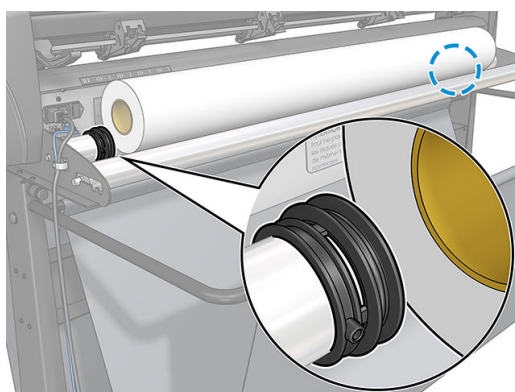

- Start feeding the substrate in from the rear of the machine. Pass the substrate underneath the pinch rollers towards the front of the cutter.
- Position the left substrate edge on the leftmost drive sleeve and check that the right substrate edge is positioned over the long drive sleeve.

 **NOTE:** If you have the 54 basic plus cutter, load the substrate as shown in the table below.

#### 54 basic plus cutter loading positions

| Position | Substrate width in mm (inches) | Margin width in mm (inches) |
|----------|--------------------------------|-----------------------------|
| 1        | 1372 (54)                      | 24 (1.0)                    |
| 2        | 1220 (48)                      | 23 (0.9)                    |
| 3        | 1000 (40)                      | 23 (1.2)                    |
| 4        | 914 (36)                       | 25 (1.0)                    |
| 5        | 762 (30)                       | 21 (0.8)                    |
| 6        | 610 (24)                       | 20 (0.8)                    |
| 7        | 500 (20)                       | 23 (1.1)                    |
| 8        | 400 (16)                       | 25 (1.1)                    |
| 9        | 280 (11)                       | 10 (0.4)                    |
| 10 *     | 105 (4.1)                      | 10 (0.4)                    |

\* Position 10 is at the extreme right, not shown in the illustration below. The substrate sensor should be disabled when using this position.

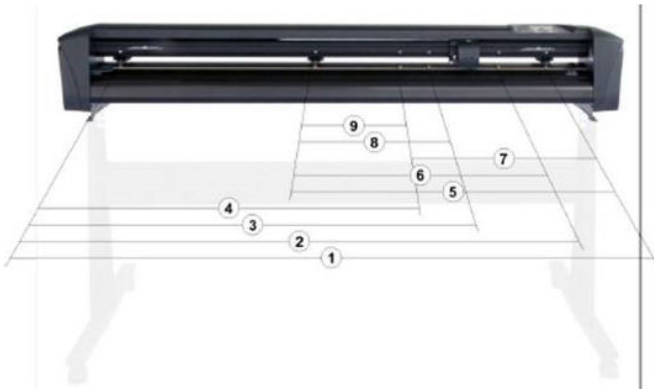

7. Position the pinch rollers over the drive sleeves about 3 to 15 mm (0.1 to 0.6 in) away from the substrate's outer edges (1). Then pull the substrate while holding the flange at the back, so that the substrate is tight.

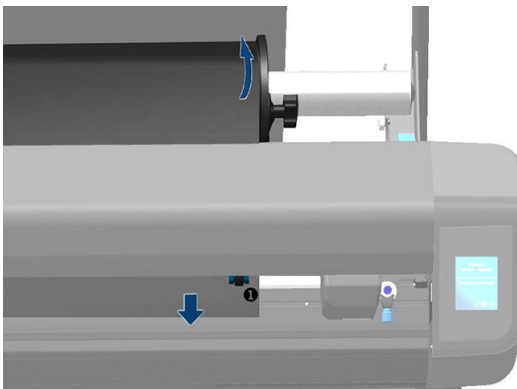

If this procedure does not work, because the substrate is too narrow to reach the long drive sleeve, position the left substrate edge over the second left drive sleeve and position the right substrate edge somewhere over the long drive sleeve. Continue moving the left pinch roller towards the long drive sleeve until both pinch rollers are in their designated position and directly over the edges of the vinyl.

In all cases, both edges of the substrate must cover a drive sleeve. If this is not the case, reposition the roll to cover the drive sleeve.

8. Make sure the substrate follows a straight path from the roll. If necessary, slide the roll and flange guides from left to right along the substrate support rollers.

---

**⚠ WARNING!** Keep fingers and other body parts away from the cutting area, where there are hazardous moving parts.

---

9. Lower the pinch-roller lever to press the substrate firmly against the drive sleeves. After one second the tool carriage automatically moves from right to left to measure the usable substrate width.

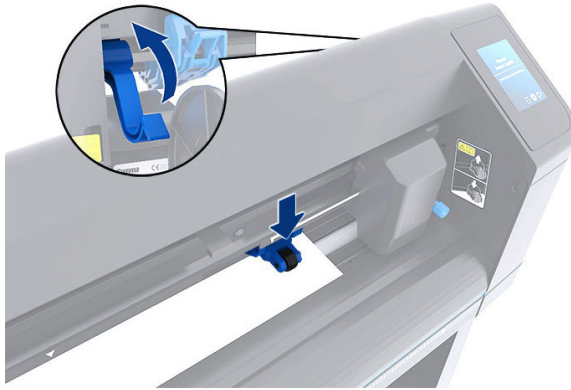

 **NOTE:** You are not recommended to unroll the substrate manually from the roll. The cutter will unroll the substrate automatically as needed.

### Load a sheet

1. Place the sheet in front of the cutter, and make sure that it is correctly aligned, using the alignment marks at front and rear.
2. Raise the pinch rollers with the pinch-roller lever arm, which is located at the right-hand side of the cutter, next to the front panel.

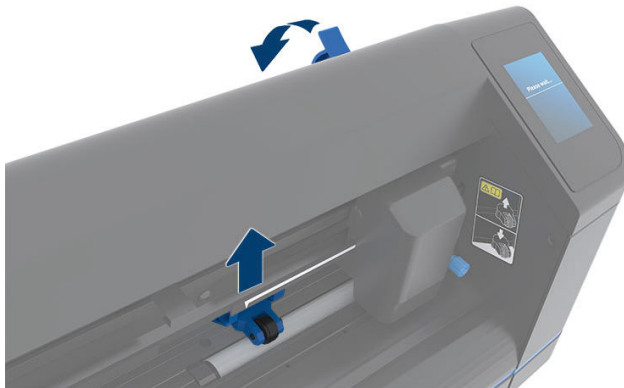

3. Start feeding the substrate in from the rear of the machine. Pass the substrate underneath the pinch rollers towards the front of the cutter.
4. Position the left substrate edge on the leftmost drive sleeve and check that the right substrate edge is positioned over the long drive sleeve.

 **NOTE:** If you have the 54 basic plus cutter, load the substrate as shown in [54 basic plus cutter loading positions on page 13](#).

5. Position the pinch rollers over the drive sleeves about 3 to 15 mm (0.1 to 0.6 in) away from the substrate's outer edges (1).

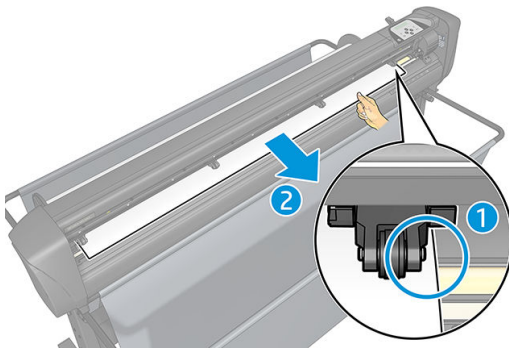

6. Lower the pinch-roller lever to press the substrate firmly against the drive sleeves. After one second the tool carriage automatically moves from right to left to measure the usable substrate width.

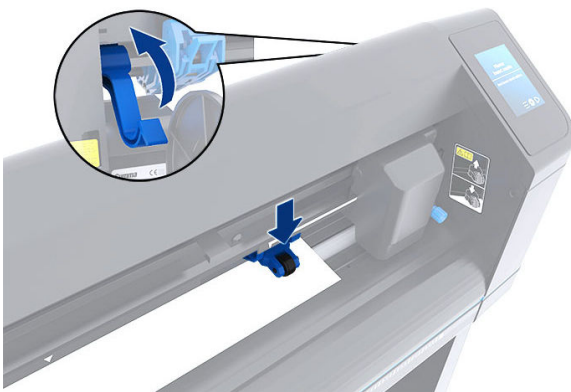

 **NOTE:** You are not recommended to unroll the substrate manually from the roll. The cutter will unroll the substrate automatically as needed.

While the cutter is activated, it will automatically start executing a minimal loading procedure as soon as the pinch rollers are lowered. The load procedure will also start if the cutter is switched on while substrate is already in the cutter and the pinch rollers are in the down position (this is not recommended). Always keep the pinch rollers in the up position while the cutter is not being used.

The cutter's minimal loading procedure consists of the following actions, for every kind of job:

- It measures the width of the substrate.
- It unwinds the substrate for a length equal to the width between the two pinch rollers.
- It makes a simultaneous 45° axial move of the drive drum (sleeves) and cutting head.

The cutter is now ready to receive jobs from the computer.

When receiving a job from the computer, the cutter automatically pulls the required substrate from the roll. It does this in steps, and the length of the vinyl used is equal to a number of times the measured width of the substrate.

This load procedure is sufficient in most cases. However, there are some extra load features available.

 **NOTE:** Tracking of longer signs can be guaranteed only when the full load procedure is performed.

## Position the pinch rollers

Proper movement of the substrate will occur only if the substrate is driven by the two outer pinch rollers, which are correctly located over two drive sleeves.

The pinch rollers are lowered or raised simultaneously by means of the pinch roller lever arm, located on the right-hand side of the cutter. The pinch rollers must be lifted to allow vinyl loading, during which the substrate is fed from the rear of the cutter to the front. When raised, the pinch rollers can be moved manually to the left or the right along the pinch roller shaft.

**CAUTION:** Always make sure that the pinch rollers are fully raised before sliding them to the left or right.

**CAUTION:** Always hold the assembly at the side of the pinch roller to move it from left to right. Do not reposition the pinch roller by holding the assembly at the rear of the machine.

The pinch rollers **must** be positioned correctly and lowered onto the substrate before an automatic load sequence is initiated. Make sure all the pinch rollers are positioned above a drive sleeve. The outer left pinch roller should be positioned in one of the detents (click positions), situated under a white triangular label. The outer right pinch roller should be positioned somewhere over the long drive sleeve. Click positions are located at the edges of the sleeve (area marked with a white triangular label).

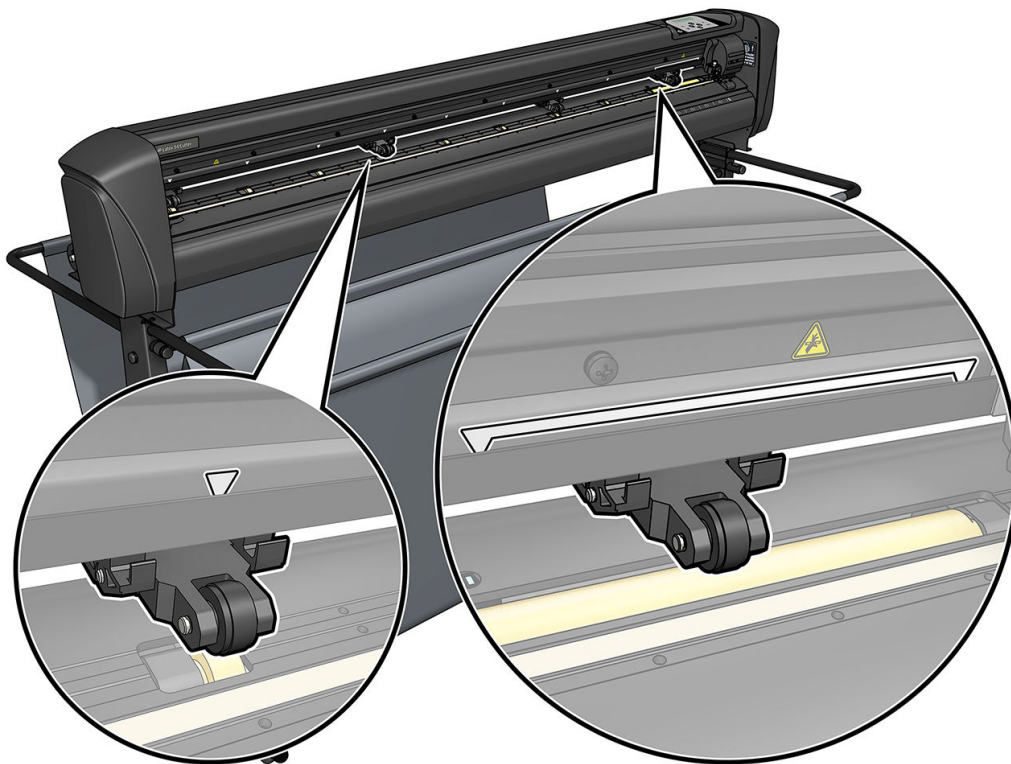

**CAUTION:** Always leave the pinch rollers in the up position when the cutter is not in use. Leaving the pinch rollers in the down position for a long time will create a flat spot on the pinch rollers, which will seriously degrade tracking performance and cutting quality.



**NOTE:** When the pinch rollers are raised during a job, the cutter will immediately stop and move the carriage to the right side.

## Calibrate the substrate

Substrate calibration ensures that the sensor is able to recognize the HP barcode and the markers. OPOS is calibrated at the factory to work on a wide range of substrates. However, certain substrates—such as those with a high gloss, or transluents—may not work with the default settings. Before working with such materials, perform a substrate calibration. This alters OPOS's sensitivity so that it can read the marks with greater reliability.

Print a calibration plot measuring 12 × 48 cm (4.7 × 18.9 in) on the substrate that will be used, by clicking **Setup > Printer Cutter Calibration Chart** in the RIP software. Be sure to use the same ink that will be used when creating the registration markers.

 **IMPORTANT:** In most cases, substrate calibration is not recommended for OPOS. If you perform the calibration and results do not improve, reset the substrate calibration value to its default setting of 30 (see below).

1. Turn on the cutter and load the substrate with the calibration plot.
2. Tap  on the front panel.
3. Scroll down, then tap **Calibrations > Calibrate substrate (OPOS) > Measure.**
4. Use the arrows to move the knife above a white area. When finished, tap  to continue.

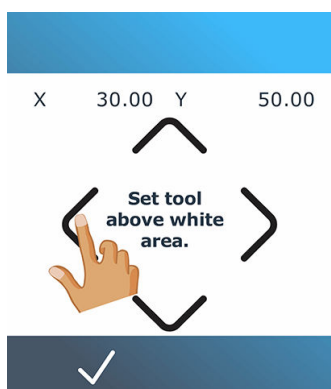

The cutter moves in a circle while measuring the reflection of the substrate.

5. Use the arrows to move the knife above a printed area. When finished, tap  to continue.

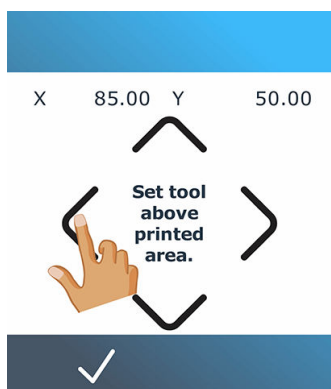

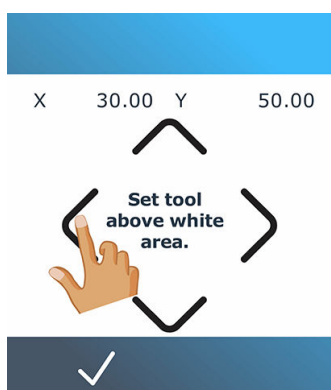

The cutter moves in a circle while measuring the reflection of the substrate.

6. Use the arrows to move the knife above a white area. When finished, tap  to continue.



The cutter moves in a circle while measuring the reflection of the mark.

- The cutter displays a value that depends on the combination of substrate color and mark color. Make a note of this value.
- Tap , then **Calibrations > Calibrate media (OPOS) > Set**.
- Use the arrows to change the value, or tap in the new value. When finished, tap  to continue.

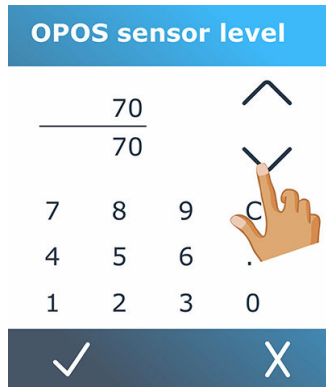

To reset the calibration to the default value, Tap , then **Calibrations > Calibrate media (OPOS) > Reset to default**.



## Adjust cutting parameters

Some parameters should be reset whenever a new substrate is loaded.

### Set knife depth and pressure

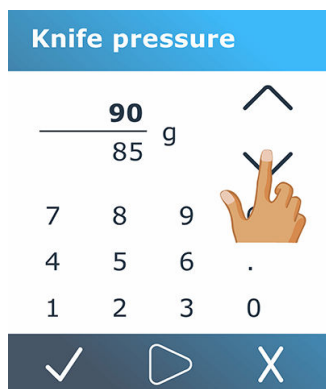
- Turn on the cutter and load the substrate.
- Tap  on the front panel.
- Use the arrows to change the value, or tap in the new value.



- Tap  to perform the internal pressure test.
- Tap  to confirm the chosen pressure.
- Tap  to leave the pressure unchanged.

- When you press , the current knife pressure is set to the new value and the cutter cuts the knife pressure test pattern.
- Peel out the rectangle and inspect the substrate backing.

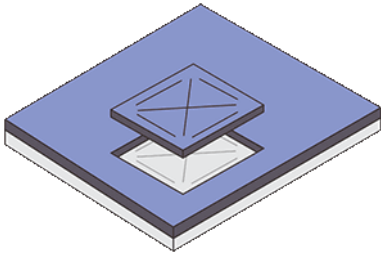

The knife depth is set correctly when the test pattern cuts completely through the vinyl and the blade tip has visibly scratched the front side of the substrate backing. The blade should never cut through the backing; just slightly scratch the silicon coating and first few fibers of the backing material.

## Set the cutting speed

The actual speed at which the tool moves is determined by four different parameters: speed and acceleration while the tool is down; speed and acceleration while the tool is up. These four parameters have been represented by just one parameter so that you can change the speed quickly and easily.



This parameter is called *velocity*; it is the speed of the cutter when the tool is down. If the velocity is raised or lowered, the other parameters are also raised or lowered accordingly. The parameters can be changed individually, but only by using the program HP Cutter Control.

 **NOTE:** The speed at which the cutter pulls the substrate from the roll is fixed at 200 mm/s (8 in/s).

### Set the velocity

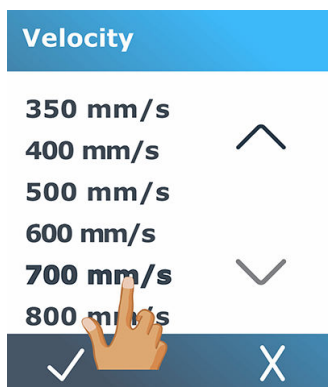
- Turn on the cutter and load the substrate.
- Tap  on the front panel.
- Tap to select the new velocity. Use the arrows to scroll, if necessary.



- Tap  to confirm the chosen velocity, or  to leave the velocity as it was before.

 **NOTE:** The cutting speed can also be set from the Settings menu.



## Perform length calibration



The cutter has been calibrated in the factory for standard 51 µm (2 mil) cast or 76 µm (3 mil) calendared vinyl. A different calibration factor can be associated with each of the four users. This is particularly helpful for multi-colored signs: it ensures that the parts in different colors match up, even if different types of vinyl are used.

For standard use, it is not necessary to calibrate the cutter. With standard vinyl, the accuracy is within 0.2%. However, if high accuracy between different vinyls is needed, then calibration is necessary.



1. Turn on the cutter and load the substrate.
2. Tap  on the front panel.
3. Scroll down and tap **Calibrations > Length calibration**.
4. The cutter reloads the substrate and starts the length calibration. Take out the substrate and measure the length of the cut line. The length to be entered is the distance between line 1 and line 2, as shown below.

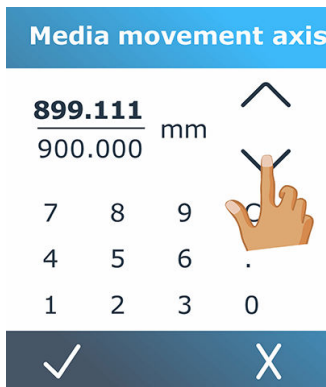

 **NOTE:** The cutter can only be as accurate as the accuracy of the calibration itself. If your measurement of the length is inaccurate, then recalibrating may reduce the cutter's accuracy. For maximum accuracy, HP recommends setting the cutter to **Metric** units of measurement for the calibration.

5. Tap  to enter your measurement, or  to cancel the calibration.
6. Use the arrows to change the value, or tap in the new value.



7. Tap  to confirm the new calibration, or  to cancel it.

 **NOTE:** When you have calibrated for one of the four users, you may find it useful to change the user name.

# Media Sensor calibration (Media Sensor Setup)

## Media sensor sensitivity calibration

Depending on the color of the backing of the media loaded in the machine, the sensitivity of the media sensor may be adjusted, to be able to detect the presence of the media.

The media sensitivity setting is stored per user configuration. It is best to choose a user configuration, then calibrate the media sensor for this kind of media.

To access the "Media sensor setup" menu to adjust the media sensor sensitivity, follow these steps:

1. Start the machine.

2. Click the **Menu** button



3. Scroll through the menu and click on **Calibrations**.
4. Select the option **Media sensor setup**.

5. Select the option **Measure**. A dialog will appear instructing to insert the media half on the sensor.

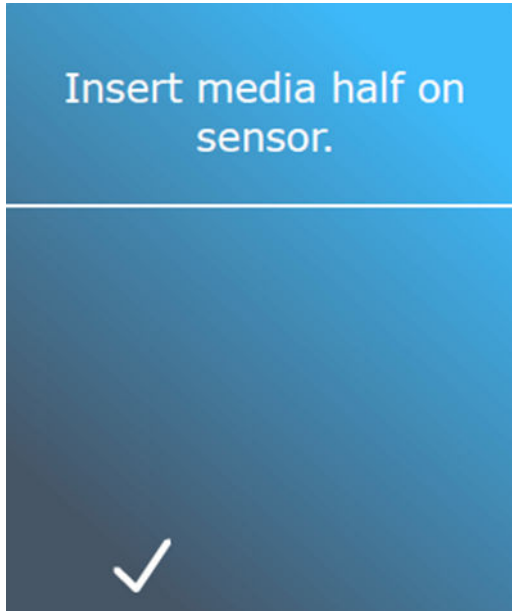

6. Load a piece of media from the front of the machine halfway on the sensor and under the two outermost pinch rollers.

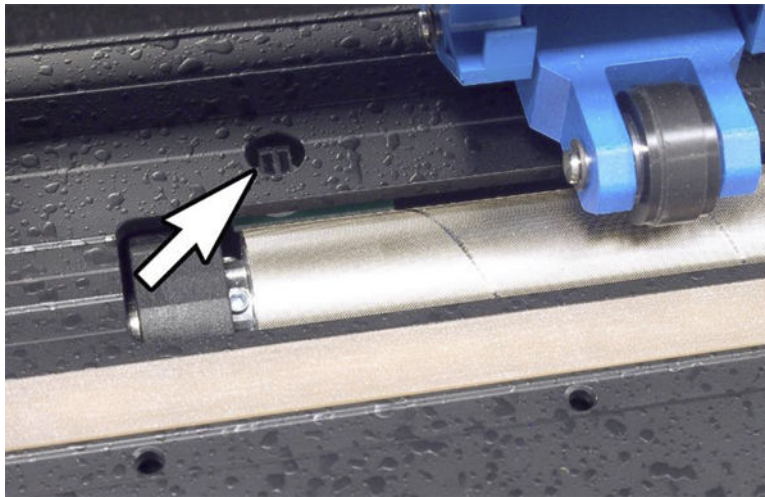

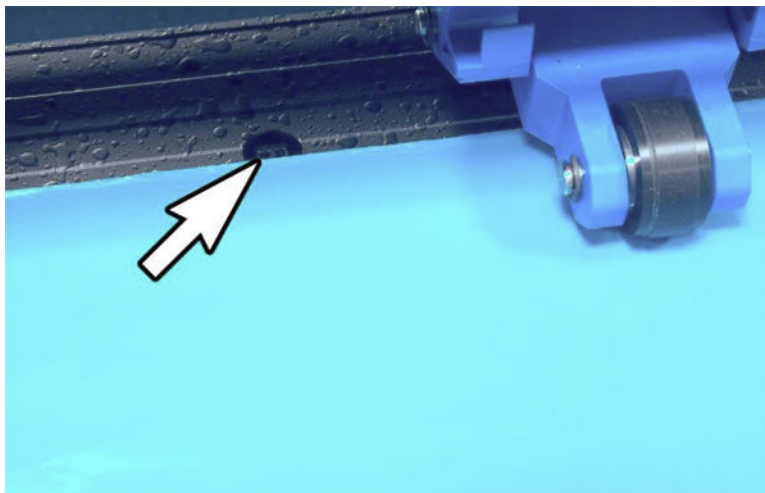

7. Lower the pinch rollers (pinch rollers need to be positioned over the grid rollers).

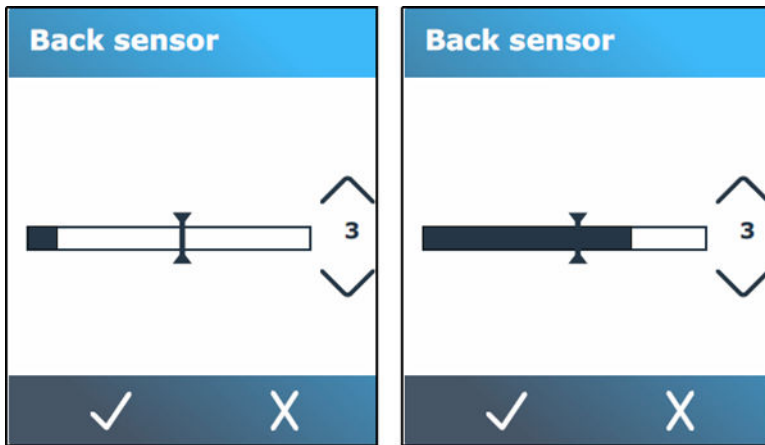

8. Press the **tick** button  to continue. The cutter moves the media backward and forward to cover and uncover the media sensor. The display alternatively shows the reflection value of the sensor when covered or not covered.



9. Use the **down** button  or the **up** button  to change the sensitivity. The sensitivity can be changed from 0 (high sensitivity) to 4 (low sensitivity). The sensitivity is correctly set when, if the sensor is covered, the bar graph is almost completely filled. When the sensor is uncovered, then the meter is (almost) empty.

 **NOTE:** The default value for the sensitivity is 3.

10. Move the **bar** slider  to set the trigger level. Ideally, the trigger level is set halfway along the bar graph when the sensor was covered and when the sensor was uncovered.

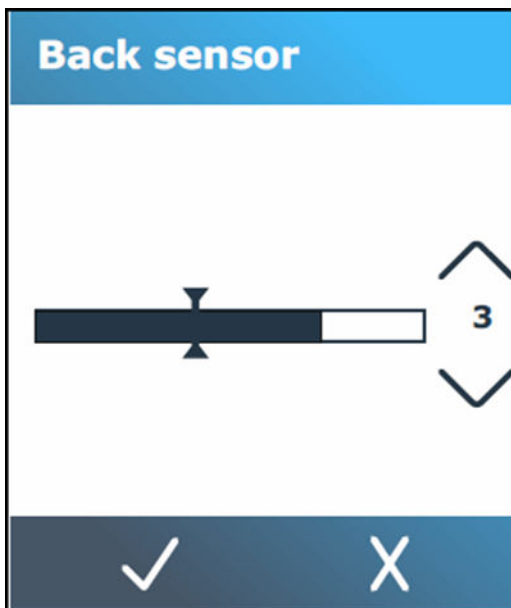

11. Press the **tick** button  to confirm the calibration.

## Media sensor activity

Alternatively, it is also possible to switch the media sensor off. The machine then assumes media is present, and will not check for the rear edge of the media. Switching the media sensor off may increase the risk of cutting in the cutting strip as the media may be fed out of the machine.

1. Power on the cutter.

2. Click the **Menu** button

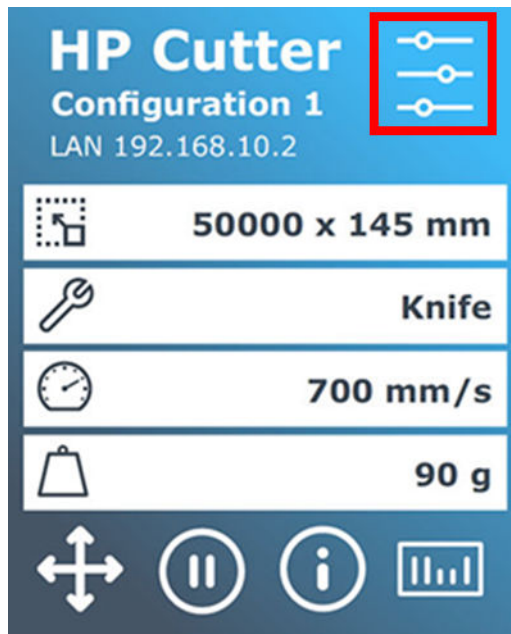

3. Scroll through the menu and click on **Configuration**.
4. Scroll through the menu and click on **Media sensor**.
5. Click on **Off** and confirm.

## Change user

There are four user configurations, all of which have the same parameters. The parameters can be set to different values for each user, so that you can reconfigure the cutter for a different type of job or substrate quickly and easily by selecting a different user.



**NOTE:** Initially, the parameters are set to the same values for all users.

These are the most important cutting parameters that can be saved for different users:

- Speed | Pressure | Offset | Tool
- FlexCut settings
- Substrate and length calibration values
- Overcut
- Paneling

## Change to a different user

1. Turn on the cutter and load the substrate.
2. Tap the name of the current user on the front panel.

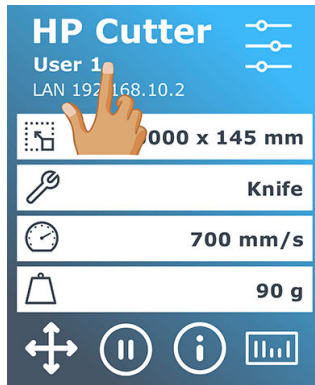

3. Select another user from the list.

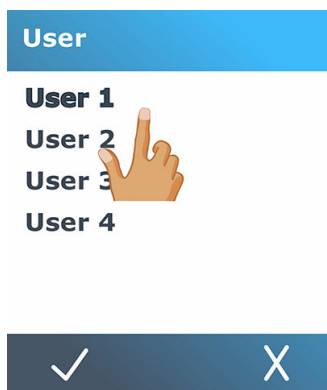

4. Tap  to confirm the new user, or  to cancel the change.

## 4 Cutting workflow

Your cutter provides full facilities to edit your cutting jobs and obtain high-quality, ready-to-use cut products.

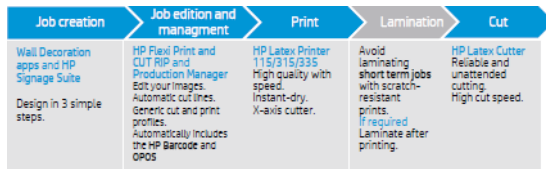

**NOTE:** The workflow described works only with jobs prepared using the software provided.

### Job types

There are different kinds of jobs: mainly, print-and-cut jobs and direct-cut jobs. Both are prepared at the computer with the software provided.

When you start a direct-cut job, the cutter will start to cut immediately, so make sure you have the substrate loaded first.

In general, contour-cutting jobs include the following steps:

1. Create the graphic and contour-cut line(s).
2. Print the graphic using the HP Printer and HP Flexi Print & Cut RIP software.
3. Load the graphic into the cutter.
4. Load the substrate and register the marks.
5. Cut the graphic.

### Cut types

The cutter is designed to make two kinds of cut.

## Kiss cut

This cuts only the substrate, and not the liner.

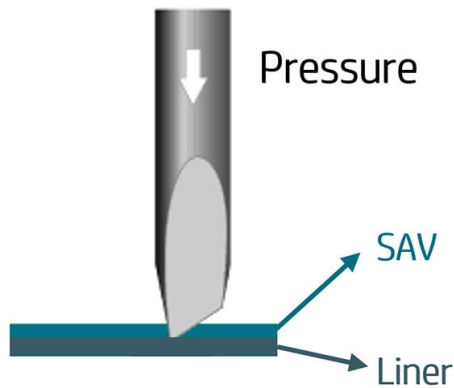

See [Set knife depth and pressure on page 19](#).

## Cut through (called FlexCut in the front panel)

This cuts all the way through the substrate and liner. Small pieces left uncut (bridges) allow the substrate to remain connected together; when the job is finished, the cut pieces can be torn out. Although this can be done with any shape, it is reliable only with simple shapes.

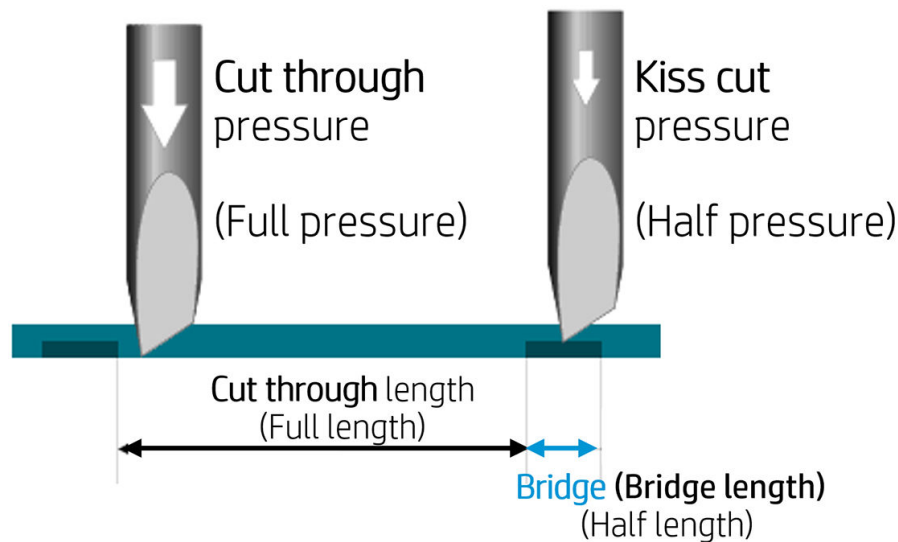

HP Flexi Print & Cut RIP can recognize the difference between a contour line and a cut-through line. The software will send the data of the contour lines to the cutter first, then activate FlexCut, panelling mode, and vector sorting, and send the cut-through data to the cutter.

The following procedure describes how to set the parameters for FlexCut. The parameters used are 180 g and 10 mm for full pressure, 100 g and 1 mm for FlexCut pressure and auto-speed as an example. The next section describes how to get the exact parameters for the substrate that you intend to use.

1. Turn on the cutter and load the substrate.

2. Tap  on the front panel.



3. Tap FlexCut.

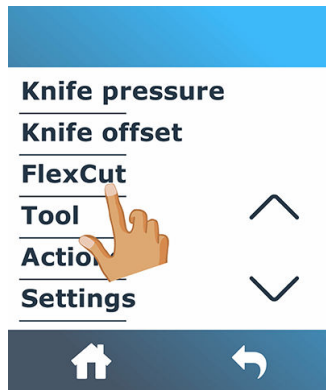

4. Select the parameter that you want to set.

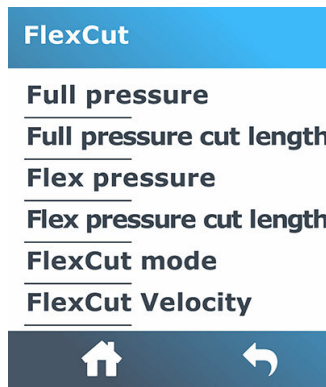

## Values of the FlexCut parameters

Determining the values of the FlexCut parameters can be divided into two main parts. The first part is to determine the 'fixed' pressure values; the second part is to determine the length parameters empirically.

### Pressure

1. Determine the pressure needed to cut completely through both vinyl and backing (see [Set knife depth and pressure on page 19](#)).
2. Raise the knife a little and check whether it still cuts completely through. If so, raise it again. If it does not cut completely through, then lower the knife to its previous position.
3. Decrease the knife pressure a little and check whether it still cuts completely through. If so, lower it again. If it does not cut completely through, increase the pressure to its previous value.
4. Fix the knife at its current position, and make a note of the final pressure.

### Length

1. In the FlexCut menu described above, set the **Full pressure** to the value that was needed to cut through the vinyl and backing, and set the **Flex pressure** to the value needed to cut through the vinyl only.

 **NOTE:** It is never recommended to use cutting speeds higher than 400 mm/s (16 in/s) with cutting pressures above 170 g. So, if the full pressure is higher, lower the FlexCut velocity.

2. Set the **Full pressure cut length** to 10 mm and set the **Flex pressure cut length** to 0.8 mm. Perform a test. Check the bridges. If they are too large, perform a test with a lower value. If they are too small (or non-existent) then raise the value.

The FlexCut parameters are now set.

If these settings need to be adjusted, try changing only the **Flex pressure cut length**. There is no need to adjust pressure settings until the knife wears down. In that case, start again from the beginning.

---

 **NOTE:** It is not always easy to find the correct balance between cutting deep enough and making sure the pieces can be taken out easily and not cutting too deep, making sure the material keeps its strength while cutting. Sometimes this balance cannot be found, meaning that there is no satisfactory way to cut through this substrate.

---

## Job editing and management (RIP)

The following sections briefly explain the steps required to prepare your job for printing and cutting.

### Job workflows

Jobs can be created with HP Signage Suite, HP Flexi Print & Cut, or any other graphic design software.

There are three main workflows:

- Files with contour marks: Direct to Production Manager HP Edition.
- Files without contour marks: Edit with HP Flexi Print and Cut Editor.
- Direct cutting: Edit with HP Flexi Print and Cut Editor.

### Adding contour marks

HP Flexi Print and Cut Editor allows you to select the paths in your image file and to add the contour marks:

 **Add contour lines > Effects > Contour cut.**

Some image types may require further steps:

- **Vectors/masks**



Remove any unnecessary background, and select only the outline paths to which you want to add a contour line.

- **Bitmaps/color traces**



For bitmaps, make the background transparent.



The Color Trace option helps to create a higher-quality contour cut.

- **Direct cut**

In this case, no contour lines are needed.



Create your design and Cut/Plot.

You can find further details in the HP Flexi Print and Cut Editor tutorial: **Help > Flexi Tutorial**.

When adding contour lines, HP recommends placing them just inside the graphics, just outside the graphics, or creating thick borders around the graphics and placing contour lines inside these borders.

## HP barcode

Contour cutting is made possible by the highly accurate Optical Positioning System (OPOS).

The OPOS sensor, which is mounted underneath the tool carriage, detects the various registration marks printed on the substrate. Using these marks, OPOS can determine the exact position of the printed graphic.

The HP barcode is the group of elements, printed on the substrate to be cut, that allow the cutter's OPOS sensor to identify what cuts should be made and where.

It consists of the following elements, which may vary depending on the options selected in the RIP software.

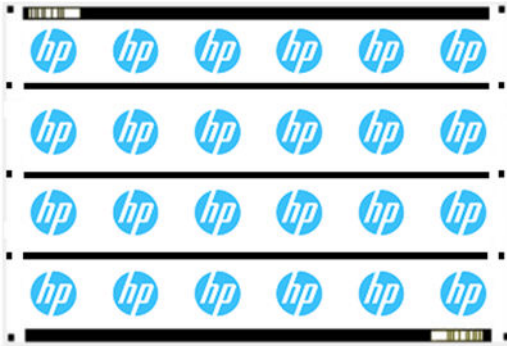



1. Registration marks: Small squares that help the cutter to locate the job accurately and to compensate for skew and deformation.
2. OPOS line(s): Lines/marks at the beginning of the job and along the job (depending on the setting) that help the cutter to compensate for deformation across the width of the job.
3. Blinking lines (HP barcode): A code that identifies the job and can be placed on both sides, improving productivity, as you can feed in the substrate starting at either end.

## Compensation method

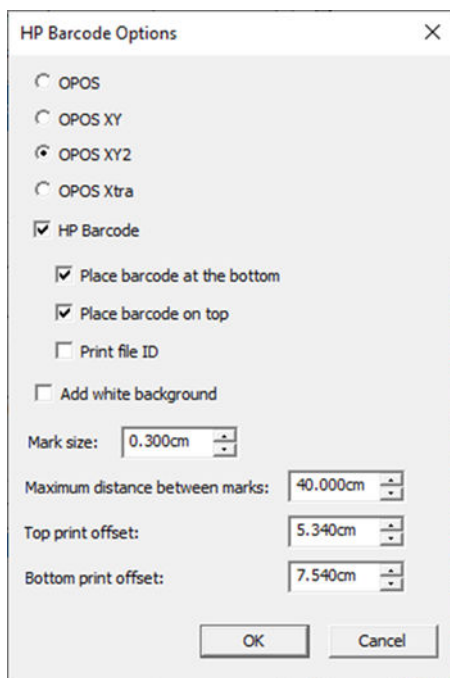
HP Workflow Options in HP Flexi Print & Cut software offer four compensation methods to help correct skew and deformation. For each option chosen, a different set of marks is printed on the plot.



| Compensation method | OPOS lines  | When to use   |
|---------------------|---|---|
| OPOS                | <p>A row of marks is printed on the left and right sides of the graphic.</p>    | No deformation of the print                             |
| OPOS XY             | <p>Registration marks and a horizontal line are printed for deformation correction. The OPOS sensor reads the bottom line to correct the deformation.</p>  | Uniform deformation in one direction (bow deformation)  |
| OPOS XY2            | <p>Registration marks and two horizontal lines are printed for deformation correction. The OPOS sensor reads both lines to correct the deformation.</p>   | Uniform deformation in two directions (bow deformation) |

## Job alignment

By default, jobs are aligned to the right of the substrate. It is important to use the same alignment for all the jobs you wish to print and cut together on the same substrate, so that the sensor can read the HP barcodes of consecutive jobs.

## Cutting parameters

Define the type of cut and the cutting parameters for each contour mark of your job according to the substrate you are using. You can change these parameters in the **Contour** menu in HP Flexi Print and Cut Editor or in the **Job properties** menu in Production Manager HP Edition.

As a starting point, you can select the cutting presets that are already stored in your HP Flexi Print and Cut Editor and Production Manager HP Edition.

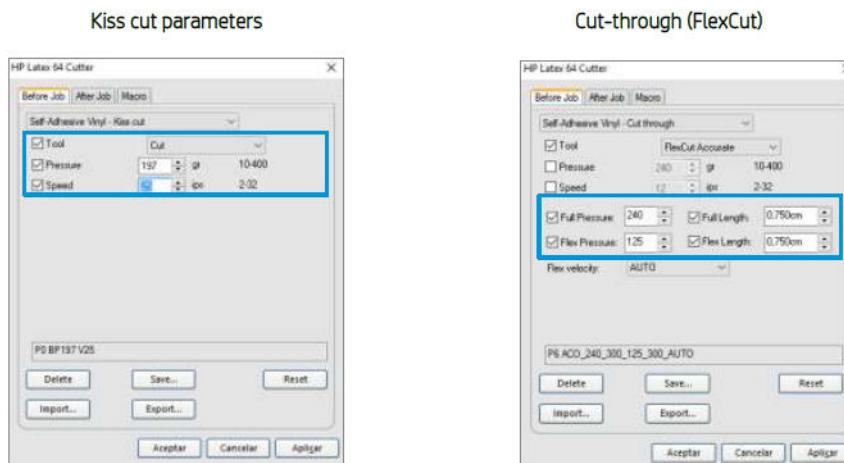

## Printing margins

When printing on a roll, make sure there is a 2 cm (0.8 in) margin at the sides and at the front. For shorter jobs, the edge margins can be smaller but should be at least 1 cm (0.4 in). When printing on a sheet, there should be at least 4 cm (1.6 in) of substrate after the last OPOS mark; this is also the minimum substrate that should be left at the end of a roll.

## Automate cutting tasks

During normal OPOS jobs you need only set the tool above the first mark to start the job. OPOS allows you to automate certain tasks, thus reducing user intervention and production time. There are several types of automation.

- **Automatic start of the OPOS job**

This is controlled by the parameter **OPOS origin**. A combination of this parameter setting and/or a special origin setting during loading of the substrate can mean that you don't need to set the tool above the first mark to start an OPOS job.

- **Multiple copies of the same job**

When cutting multiple graphics, you need only place the OPOS sensor above the origin mark of the first graphic. You do not need to do this for subsequent graphics.

There are two situations in which this can be done:

- When cutting multiple graphics, or multiple copies of a graphic, on the same roll of substrate.
- When cutting the same graphic on multiple sheets of substrate.

Most automated tasks are organized from within the cutting software. However, when the same graphic contour needs to be cut out, the automatic tasks may also involve some manual manipulation.

Before using the automation features, note the amount of your cutter's RAM. If the cutter's RAM is greater than the job's file size, then the automating features can be used. If the cutter's RAM is less than the job's file size, the automation features should not be used.

## Processing long jobs

Normally the OPOS sensor registers all the marks before it starts cutting. However, with long jobs that can result in extensive back-and-forth feeding of the substrate, which is bad for tracking. There an extra parameter can be set in the cutter. With this option, the job can be divided into panels in order to avoid moving the substrate unnecessarily. When OPOS panelling is activated, all cut data will be cut in panels. The size of the panel will be the distance between the OPOS marks in the X-axis (along the substrate-advance direction).

OPOS panels can be set to OFF, ON (2 marks), or ON (4 marks). When set to ON (2 marks), the cutter will load only 2 marks in the X direction when loading OPOS, and read the marks (4 in total for the first panel). The following panels will then be cut after reading the marks at the end of that panel (so 2 for each following panel). When set to ON (4 marks), the last marks of the previous panel are re-read. This improves the connection between the panels.

1. Turn on the cutter and load the substrate.
2. Tap  on the front panel.
3. Scroll down and tap **Configuration** > **OPOS parameters** > **OPOS panelling**.

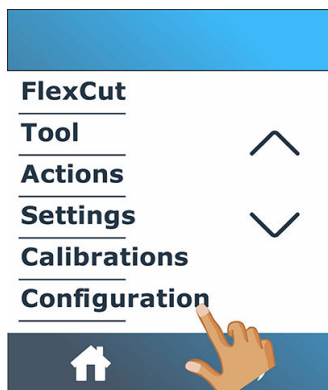

4. Select 2 or 4 marks.

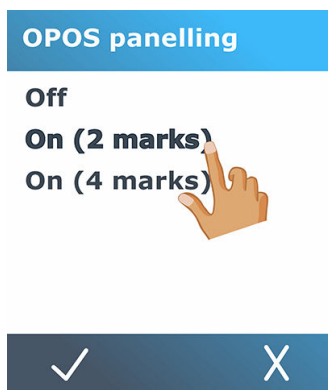

5. Tap  to confirm, or  to cancel.

## OPOS origin

The parameter **OPOS origin** was created to automate the start of the OPOS procedure. This parameter has four settings. Its usage depends on the chosen OPOS mode. It can be found in the system submenu **OPOS parameters**. If the OPOS mode is **OPOS barcode** or **OPOS sheet**, then **OPOS origin** has no effect. The useful combinations are mentioned in the table below.

|                     | OPOS X           | OPOS XY             |
|---------------------|------------------|---------------------|
| Mark                | Indicate mark    | Indicate mark       |
| XY correction line  | –                | Indicate line       |
| Current position    | Current position | Current position    |
| Center of substrate | –                | Center of substrate |

### In combination with OPOS X mode

- **OPOS origin is set to ‘Mark’**

This is the default setting. On receiving an OPOS job from the computer, the cutter prompts you to set the tool above the first mark and tap **Apply**. The cutter then starts searching for the OPOS mark around that position.

- **OPOS origin is set to ‘Current position’**

On receiving an OPOS job from the computer, the cutter immediately starts looking for the mark, without waiting for you to move the tool. Therefore, you have to position the tool above the first mark while loading the substrate.

If OPOS origin is set to either **XY correction line** or **Center of substrate**, the cutter reacts as though the parameter were set to **Indicate mark**.

### In combination with OPOS XY mode

- **OPOS origin is set to ‘Mark’**

This is the default setting. On receiving an OPOS job from the computer, the cutter prompts you to set the tool above the first mark and tap **Apply**. The cutter then starts searching for the OPOS mark around that position.

- **OPOS origin is set to ‘Indicate line’**

On receiving an OPOS job from the computer, the cutter prompts you to set the tool under the OPOS XY line and tap **Apply**. The cutter then starts searching for the OPOS XY line by slowly advancing the substrate. Once it finds the OPOS XY line, it follows this line to the right until it finds the first mark and can start searching for the actual mark.

- **OPOS origin is set to ‘Current position’**

On receiving an OPOS job from the computer, the cutter immediately starts searching for the OPOS XY line by slowly advancing the substrate. Once it finds the OPOS XY line, it follows this line to the right until it finds the first mark and can then start searching for the actual first mark. Therefore, you should set the origin under the OPOS XY line, immediately after the substrate has been loaded.

This setting was created for jobs that are aligned to the left and vary considerably in size on the roll. The origin/tool can then be set to the left of the substrate, under the OPOS XY line in order to be able to find the origin mark, even if it is situated far from the right.

- **OPOS origin is set to ‘Center of substrate’**

On receiving an OPOS job from the computer, the cutter first sets the OPOS sensor in the center of the substrate. Then it starts searching for the OPOS XY line by slowly advancing the substrate. Once it finds the XY line, it follows the line to the right until it finds the first mark, and can then start searching for the actual mark.

This setting has been created for jobs on a roll where the width of each job is at least half the width of the substrate (this is usually the case, otherwise there is a lot of wasted substrate). This method is slightly slower than the previous method.

## Read the HP barcode



Some RIPs can print a barcode together with the OPOS markers. This barcode can then be used to identify the job and retrieve the cut data automatically from the computer.

The complete procedure is normally started from the computer. The RIP software usually has a button or a command called **Scan a barcode**. First make sure the substrate is loaded. Then skip to step 3 in the following procedure.

It can also be started from the cutter, as follows:

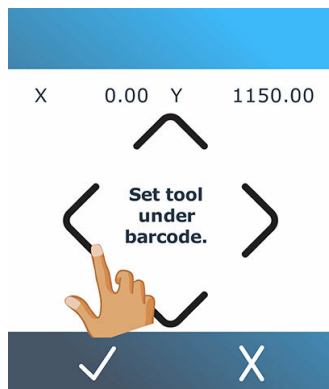
1. Turn on the cutter and load the substrate.
2. Tap  on the front panel.
3. Use the arrows to put the knife under the barcode.



4. Tap  to confirm, or  to cancel.
5. The cutter reads the barcode and sends the data to the computer.
6. The cutting software automatically sends the correct cutting data to the cutter.
7. The cutter starts sensing the OPOS marks, and cuts out the job.
8. The OPOS sensor looks for another job printed after the one that has just finished, and continues to contour-cut.
9. This is repeated until all contour-cut jobs on the loaded roll are cut out.



# Calibrate the OPOS

To ensure that the OPOS is working accurately, two calibrations are necessary: OPOS calibration and substrate calibration. OPOS calibration is the calibration of the distance between the knife tip and the sensor. Substrate calibration teaches the cutter the reflection levels of the mark color and the substrate color. See [Calibrate the substrate on page 17](#).



 **NOTE:** Although the OPOS sensor has been calibrated in the factory, HP recommends testing how well the factory-set parameters work with the materials you are using. If the accuracy is not sufficient, then perform the OPOS calibration.

1. Turn on the cutter and load black vinyl with white backing.

 **NOTE:** Black vinyl with white backing must be used when calibrating OPOS.

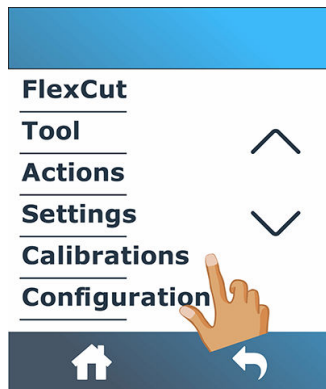
2. Tap  on the front panel.
3. Scroll down and tap **Calibrations** > **Calibrate OPOS**.



4. The cutter cuts out a square, measuring approximately 9.5 × 9.5 mm, and moves the square forward. **Weed out the rectangle** appears on the front panel.
5. Carefully remove the square, making sure the edges remain intact.
6. Tap .
7. Tap  to get online again.
8. The OPOS read the edges of the square and calibrates itself accordingly.
9. Tap  to get online again.

 **NOTE:** To keep the accuracy of the OPOS sensor as high as possible, repeat this calibration each time the knife is replaced.

## Change the origin

1. Turn on the cutter and load the substrate.
2. Tap  on the front panel.
3. Use the arrows to change the origin. The value of Y is the width that is left.

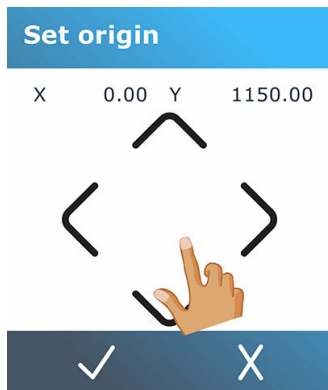

4. Tap  to confirm, or  to cancel.

## Extended load

The extended load function allows you to extend the limits of the Y axis so that the cutter can cut outside the pinch rollers. The substrate must be loaded before this function can be used.

 **NOTE:** Tracking is not guaranteed when using this function.

1. Turn on the cutter and load the substrate.
2. Tap  on the front panel.
3. Tap **Actions** > **Load extended**.

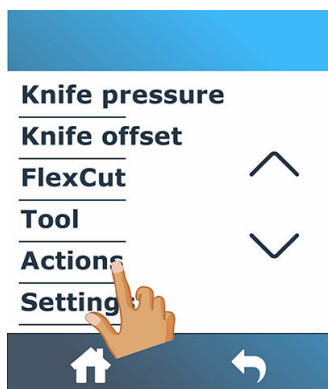

4. Use the arrows to set the origin, and tap  to confirm.

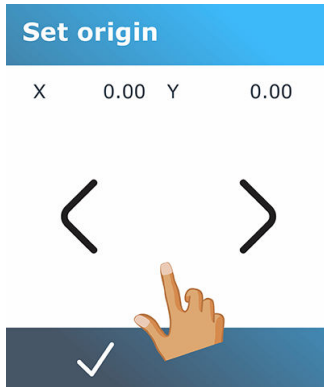

5. Use the arrows to set the size, and tap  to confirm.

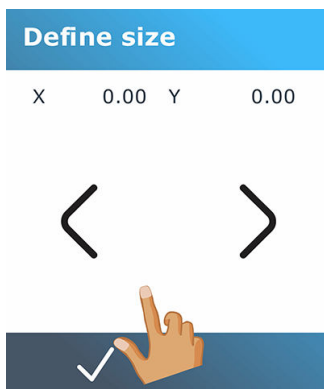

# 5 Detailed operation of the cutter









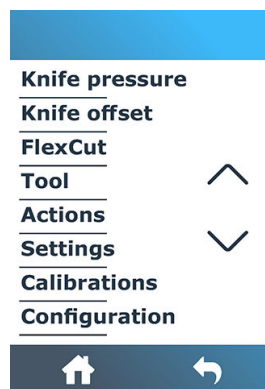
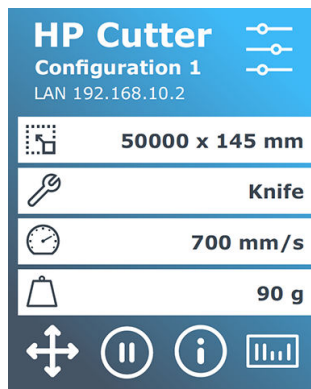



## Introduction







This chapter contains a detailed list of all parameters that can be changed and tests that can be initiated from the cutter's front panel.







The commonly used front-panel operations have already been described in this guide. This chapter may be used as a reference to locate a particular parameter setting or test, including the less frequently used items.

The menu system consists of the home screen, the main menu, and the eight subsidiary menus.



| Knife pressure  | Knife offset  | FlexCut   |
|---|---|---|
| <p><u>90</u> g </p> <p>85 </p> <p>7 8 9 C</p> <p>4 5 6 .</p> <p>1 2 3 0</p>         | <p><u>0.42</u> mm </p> <p>0.41 </p> <p>7 8 9 C</p> <p>4 5 6 .</p> <p>1 2 3 0</p>    | <p><u>Full pressure</u></p> <p><u>Full pressure cut length</u></p> <p><u>Flex pressure</u></p> <p><u>Flex pressure cut length</u></p> <p><u>FlexCut mode</u></p> <p><u>FlexCut Velocity</u></p>   |
|    |    |    |

| Tool  | Actions   | Settings  |
|---|---|---|
| <p>Pen</p> <p>Knife</p>   | <p><u>OPOS Barcode</u></p> <p><u>Confidence test</u></p> <p><u>Load</u></p> <p><u>Load extended</u></p> <p><u>Replot</u></p> <p><u>Reset</u></p>                    | <p><u>Velocity</u></p> <p><u>Overcut</u></p> <p><u>Opticut</u></p> <p><u>TurboCut</u></p> <p><u>Panel</u></p>   |
|   |   |   |

| Calibrations  | Configuration  |
|---|--|
| <p><u>Calibrate media (OPOS)</u></p> <p><u>Calibrate OPOS</u></p> <p><u>Length calibration</u></p> <p><u>Media sensor setup</u></p>                                     | <p><u>Ethernet</u></p> <p><u>USB port</u></p> <p><u>OPOS parameters</u></p> <p><u>Factory defaults</u> </p> <p><u>Autoload</u></p> <p><u>Recut offset</u> </p> <p><u>Media sensor</u></p> <p><u>Alignment mode</u></p> |
|   |    |

## Home screen

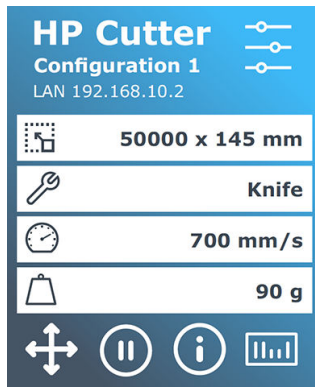

See [Front panel on page 9](#).

## Main menu

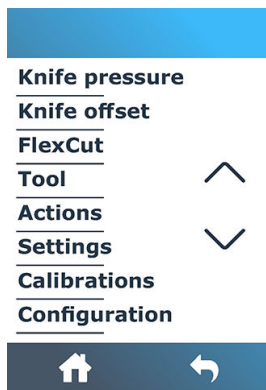

The main menu gives access to the eight subsidiary menus.

## Knife pressure

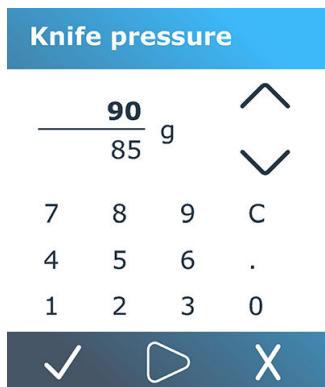

See [Set knife depth and pressure on page 19](#).

## Knife offset

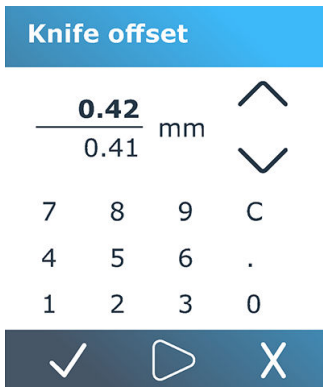

See [Change the drag knife offset on page 53](#).

## FlexCut

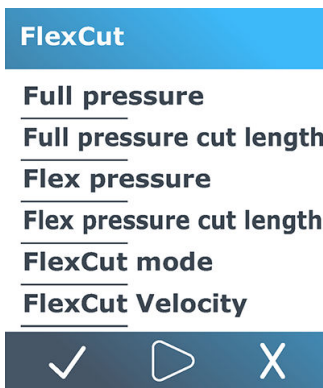

FlexCut can be set to **Off**, **Fast**, or **Accurate**. When the cutter is set to **Fast** or **Accurate**, it will alternately cut a certain length with full pressure and a certain length with reduced pressure. The advantage of the FlexCut feature is that it cuts completely through the substrate. Moreover, it also allows the material to stay together by means of the small substrate bridges.

- **Fast** is the quickest mode, but it is less precise due to the pressure changes during the cutting procedure.
- **Accurate** is much slower, but much more precise because the cutter stops at every change of pressure.

There are five typical FlexCut parameters:

- **Full pressure:** This parameter determines full pressure, used during FlexCut mode.
- **Full pressure cut length:** This parameter determines the length that is cut with full pressure, usually the length that will be cut all the way through.
- **Flex pressure cut length:** This parameter determines the length that will be cut with reduced pressure or without pressure. This is usually a much smaller value than the full pressure cut length: the length of the substrate bridges.
- **FlexCut pressure:** This parameter determines the pressure of the Flex pressure cut length. This is usually a reduced pressure, so that the knife only scratches the substrate or cuts it only halfway through.
- **FlexCut velocity:** FlexCut uses higher knife pressures. Higher knife pressures need lower cutting speed. With this parameter the velocity of FlexCut can be set independently from the normal cutting velocity.

See [Cut through \(called FlexCut in the front panel\) on page 28](#) for more details.

## Tool

### Tool

Pen  
Knife



See [Replace the knife on page 52](#).

## Actions

### Actions

**OPOS Barcode**  
**Confidence test**  
**Load**  
**Load extended**  
**Replot**  
**Reset**



- **OPOS barcode:** Has the same effect as  on the home screen: see [Read the HP barcode on page 36](#).
- **Confidence test:** A quick electrical and mechanical test of the cutter to make sure it is fully operational. A sheet of substrate of at least A3/B size should be used for this test. The sheet is always cut on the left side.
- **Load:** Load a substrate sheet. While loading, you can set the maximum substrate length.
- **Load extended:** See [Extended load on page 38](#).
- **Replot:** Recuts the last file sent to the cutter (unless it was too big for the buffer).
- **Reset:** This performs a complete reset of the cutter.



# Settings

**Settings**

**Velocity**

**Overcut**

**Opticut**

**TurboCut**

**Panel**

Home   Back

## Velocity

This menu groups all the parameters that affect the throughput of the cutter. The velocity and acceleration settings are explained in [Set the cutting speed on page 20](#).

## Overcut

The **Overcut** submenu enables you to generate an overcut to facilitate weeding the cut. Each time the knife goes up or down, the cutter cuts a bit further. The illustration below shows what overcut can do with a tangential knife. A sample cutout with a drag knife would show fewer overcuts as there would be fewer up/downs (usually only one per curve/letter). The overcut setting can be disabled (=0) or set to any value between 0 (=off) and 10. One unit is about 0.1 mm (0.004 in).

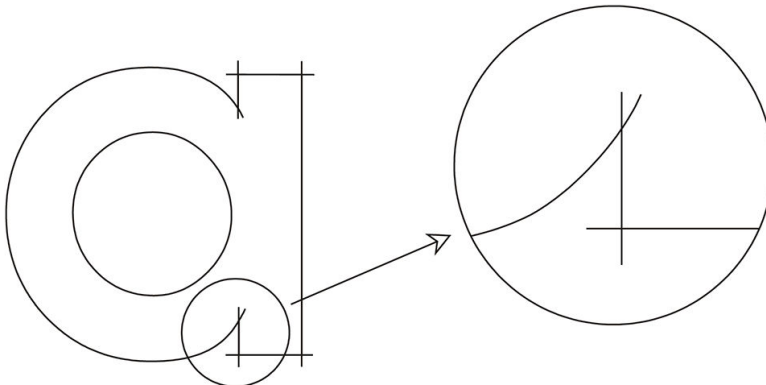

Tap . Use  to change the value. Tap  to confirm or  to cancel. The default overcut is set to 1.



## OptiCut

**OptiCut** improves the cutting quality if the knife is worn out or not calibrated correctly.

Tap . Use  to set **OptiCut** on or off. Tap  to confirm or  to cancel. **OptiCut** is off by default.

## TurboCut

TurboCut increases throughput by speeding up the drag movement but without raising the overall speed of the cutter. The cutting time reduction is significant, especially when cutting small, detailed designs. However, some thicker materials may not cut well with this feature turned on.

Tap **TurboCut**, then use  to activate or deactivate TurboCut. Tap  to confirm or  to cancel. TurboCut is activated by default.

## Panel

There are four parameters in the Panel submenu:

- **Paneling:** This parameter switches panels on or off.



---

**NOTE:** With OPOS Xtra, paneling is always on.

---

- **Panel size:** This parameter determines the length of the panel.
- **Panel replot:** This parameter determines whether the design is to be cut more than once, panel per panel. Panel replot is used for substrates that are thick or difficult to cut. The value of this parameter is disregarded if paneling is set to off. If this parameter is set to 0, the cutter cuts each panel once only. If it is set to 1, the cutter cuts each panel twice.
- **Sorting vectors:** See below.

### Sorting vectors

Sorting vectors is a submenu of the Panel menu, but because of its importance it is explained separately. There are three options in this menu:

- **Off:** When vector sorting is set off, the cutter does no optimizing of the vectors. This is used when the intelligence of the cutter driver is preferred.
- **Directional:** If set to directional, the vectors are optimized for the cutting direction (substrate advance). This is used when the cutting pressure has to be set relatively high (for example during cutting through).
- **Starting point:** This option optimizes the starting point for closed curves. This is used when the users sees that the curves do not close as they should.

Paneling is used for various different applications. Below are the typical settings for the two most common applications:

- Cutting through: This is explained in [Cut through \(called FlexCut in the front panel\) on page 28](#). Typical settings for the parameters are: **Panels: On; Panel size: 5–10 cm; Panel replot: Off; Vector sorting: Directional.**
- Tracking difficult substrates: Typical settings for the parameters are: **Panels: On; Panel size: 3–10 cm; Panel replot: On/Off**, depending on the thickness of the substrate. **Vector sorting: Directional/Off**, depending on the required knife pressure and the substrate backing.

# Calibrations

## Calibrations

### Calibrate media (OPOS)

### Calibrate OPOS

### Length calibration

### Media sensor setup



- **Calibrate media (OPOS):** Substrate calibration helps the sensor to recognize the markers. It is explained in [Calibrate the substrate on page 17](#).
- **Calibrate OPOS:** OPOS calibration calibrates the distance between the OPOS sensor and the knife tip. It is explained in [Calibrate the OPOS on page 37](#).
- **Length calibration:** Length calibration allows the length of the cut lines to be adjusted within specifications. For instance, if a cut line should measure 100 mm exactly, the cutter can be adjusted for any discrepancy. This calibration is explained in [Perform length calibration on page 21](#).
- **Media sensor calibration:** Depending on the color of the backing of the media loaded in the machine, the sensitivity of the media sensor may be adjusted, to be able to detect the presence of the media. The media sensitivity setting is stored per user configuration. It is best to choose a user configuration, then calibrate the media sensor for this kind of media. See [Media Sensor calibration \(Media Sensor Setup\) on page 22](#).

# Configuration

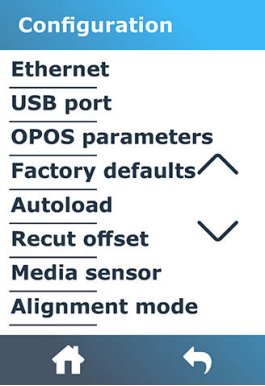



## Ethernet

This displays the cutter's Ethernet settings: DHCP, IP address, and subnet.

## USB port

The USB port can be set to **USB port 1**, **USB port 2**, **USB port 3**, or **USB port 4**.

Because of the different USB ports, the computer can distinguish between up to four cutters attached to it.

Tap . Use  to change the USB port. Tap  to confirm or  to cancel. The default setting is **USB port 1**.

---

 **NOTE:** A change in USB port takes effect only after restarting the cutter.

 **NOTE:** The USB port in the cutting software should match the USB port in the cutter. Each time a new USB port is selected for the cutter and connected for the first time to the computer, Windows starts a wizard to install the driver.

---

## OPOS parameters

The OPOS settings submenu is used to change the various OPOS parameters from the front panel.

### Extra parameters

- **Sheet mode.**
- **Paneling** allows the markers to be read in panels. Using this option, the OPOS sensor reads markers according to panel size, instead of loading them all.  
  
**Paneling** can be set to **On** or **Off**. When set to **On**, the sensor will load only two markers in the X direction when loading OPOS. Other markers will be read when unrolling substrate.  
  
The panel size is automatically set to the distance between two markers in the X direction.
- **OPOS origin** is explained in [OPOS origin on page 35](#).

## Factory defaults

This restores all parameters to the values originally set in the factory.

## Autoload

This turns autoload **On** or **Off**. It is **On** by default.

When autoload is on, the cutter automatically unrolls the vinyl when needed.

When autoload is off, you should manually unroll enough substrate before starting to cut.

---

 **IMPORTANT:** Tracking is not guaranteed when autoload is off.

---

## Recut offset

This allows you to change the distance between jobs when making multiple recuts. The default value is 40 mm (1.57 in).

## Media sensor

This turns the substrate sensor **On** or **Off**.

The substrate sensor detects whether substrate is loaded. It also detects the end of the substrate. Use of the sensor can prevent damage to the cutting strip and knife tip.

The cutter stops during the loading procedure or while it is cutting as soon as the rear sensor detects the end of the substrate.

In some cases, when using transparent substrates or dark colored substrates the cutter might not be able to detect the media loaded. In these cases, disable the media sensor and the loading procedure will start right after lowering the pinchwheels. When disabling the media sensor, the cutter advances the media a preset distance during the loading process. This preload length is equal to the media width plus 200 mm (with a maximum of 750 mm).

Tap . Use  to turn the sensor **On** or **Off**. Tap  to confirm or  to cancel. The sensor is **On** by default.

## 6 Maintenance

### Clean cutter surfaces

The cutter has a number of sliding surfaces, made of smooth metals and plastics. They are virtually friction-free and require no lubrication. They will, however, collect dust and lint that may affect the cutter's performance. Keep the cutter as clean as possible by using a dust cover. When necessary, clean the unit with a soft cloth, dampened with isopropyl alcohol or mild detergent. Do not use abrasives.

 **NOTE:** If you are in an area (such as California) that regulates VOC cleaning and maintenance fluids, instead of isopropyl alcohol use a VOC-certified cleaner such as a properly diluted Simple Green All-Purpose Cleaner.

### Clean the drive system

Over time, the sleeves of the drive drum may become clogged with accumulated residue from the substrate liner. This may cause the substrate to slip between the pinch rollers and the drive sleeves, resulting in decreasing traction.

1. Make sure there is no substrate loaded in the cutter.
2. Turn off the cutter and disconnect it from the mains. Raise the pinch rollers.
3. Put a pinch roller above the sleeve that needs to be cleaned. Make sure it is the outer left or the outer right pinch roller (otherwise there is not enough pressure).
4. Remove the backing from a piece of vinyl. Place the piece of vinyl between a pinch roller and a drive sleeve with the tacky side down. Lower the pinch roller.
5. Turn another yellow drive sleeve manually, so that the piece of vinyl is winding on the sleeve for at least one turn.
6. Pull the piece of vinyl from underneath the pinch roller.
7. Repeat several times until all residue is removed from the drive sleeves.

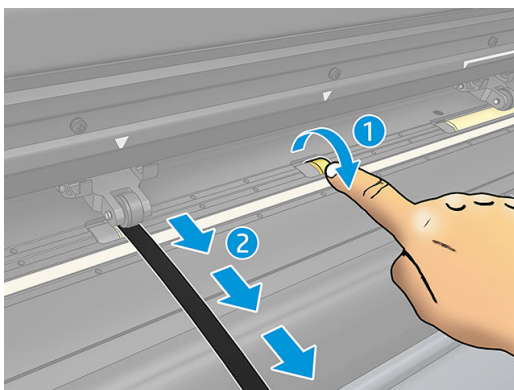

## Clean the substrate sensor

Over time, the substrate sensor may become dirty with accumulated residue from the substrate, which may cause the cutter to malfunction.

Clean the sensor by wiping it with a cotton swab.

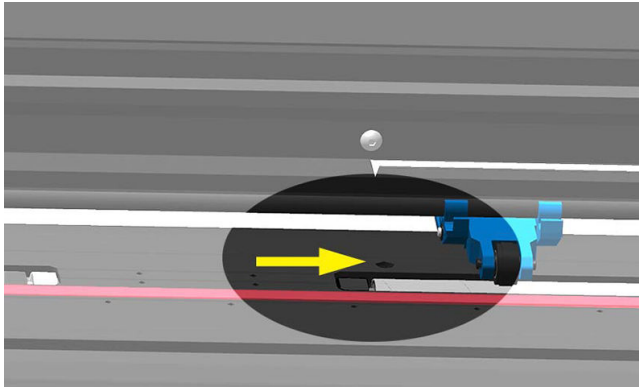

## Clean the Y-guide rail

There are two V-shaped areas on the Y-guide rail on which the tool carriage slides from left to right. The areas are on the top and on the bottom of the front of the Y guide.

Although the shape of the Y-guide rail may differ from model to model, the areas are located in the same place at the top and bottom of the guide.

The illustration below shows the top of the Y guide.

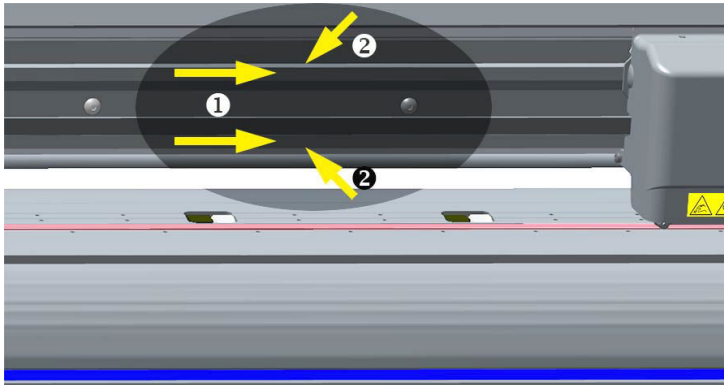

Over time, there may be some accumulated residue on these sliding surfaces and on the rollers of the tool carriage.

### Clean the sliding surfaces

1. Turn off the cutter.
2. Take a soft cloth, dampened with isopropyl alcohol or mild detergent.

 **NOTE:** If you are in an area (such as California) that regulates VOC cleaning and maintenance fluids, instead of isopropyl alcohol use a VOC-certified cleaner such as a properly diluted Simple Green All-Purpose Cleaner.

3. Clean the surfaces. When the tool carriage is in the way, push it gently to the left or right.

# Replace the knife

**⚠ WARNING!** The cutter uses razor-sharp knives. To avoid serious injury, be careful when installing, removing, or handling the knife.

## Remove the drag knife

1. Loosen the head clamp screw (1), swing the clamp arm back, and remove the knife holder from the clamp (2).

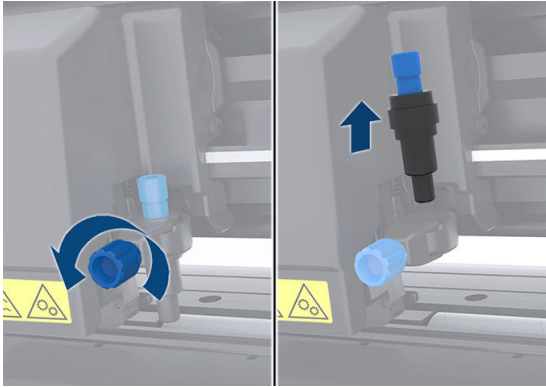

2. Turn the knurled adjustment knob (3) clockwise to push the knife (4) out of the holder (5).



3. Carefully pull the knife from the holder.

## Install the drag knife

1. Remove the aluminum piece from the plastic knife holder (5) by turning the knurled adjustment knob (3) counterclockwise until the aluminum piece comes out of the holder.
2. Insert the conical, non-cutting end of the knife into the opening in the narrow end of the holder. Gently push the knife all the way in.
3. Turn the holder upside down and tap it lightly on a solid surface to ensure the knife is completely inserted.
4. Slowly turn the knurled knob clockwise until the tip of the blade extends the distance required for the desired cutting substrate ( $t$ ), as shown in figure below.

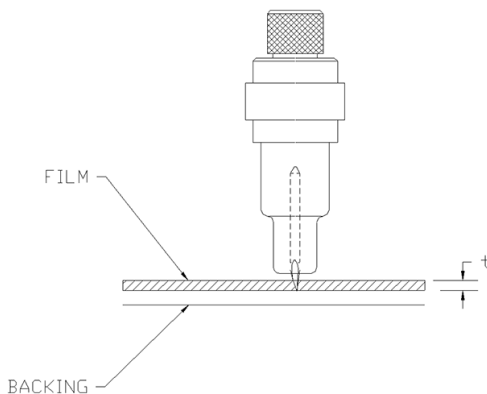



5. Insert the knife holder into the head clamp and push it all the way down (1).

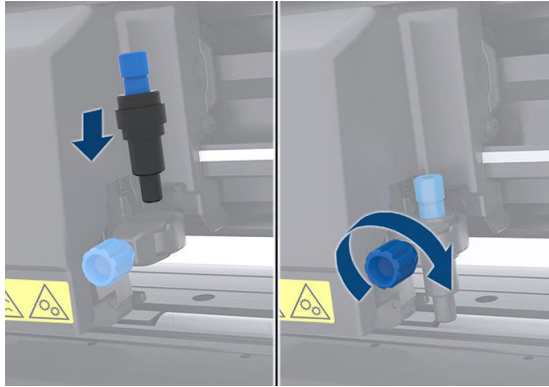

6. Tighten the clamp screw (2).

---

 **WARNING!** Take care not to cut yourself.

---

After installing a new knife, you should set the knife offset (see below) and recalibrate the OPOS sensor (see [Calibrate the OPOS on page 37](#)).

## Change the drag knife offset

The offset is the distance between the center of the knife and its tip. The offset should be set whenever the knife is changed, and should be checked if the knife shows signs of wear.

### Typical offsets







- 0.41–0.45 for standard knives
- 0.49–0.52 for the 60 degree knife
- 0.90–0.97 for sandblast knives

---

 **NOTE:** A sandblast knife should be used when the substrate is thicker than 0.25 mm (0.01 in).

---

### Change the offset

1. Turn on the cutter, load substrate, and mount the tool.
2. Press .
3. Use  to scroll through the menu until you reach **Knife offset**. Tap . The current offset appears on the screen.
4. Use  to change the offset.
  - Use  and select Down to perform the internal knife offset test.
  - Tap  to confirm the chosen offset.
  - Tap  to leave the offset unchanged.

When the offset is correct, the test pattern looks like this:

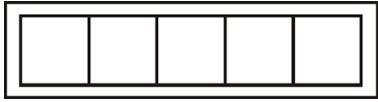

When the offset is too low, the test pattern looks like this:

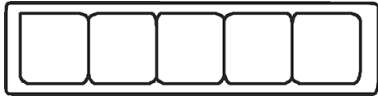

When the offset is too high, the test pattern looks like this:

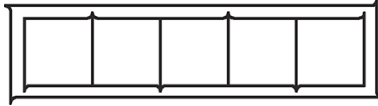

## Change the fuse

**⚠ WARNING!** Before changing the fuse, turn off the cutter and ensure that it is completely disconnected from its power source.

**⚠ WARNING!** For continued protection against risk of fire, replace only with the same type and rating of fuse: T2.0A, 250V Schurter SPT or equivalent.

1. To remove the fuse (3), lightly pry the fuse holder release clip (2) in the direction opposite the power switch. The fuse holder will pop free.

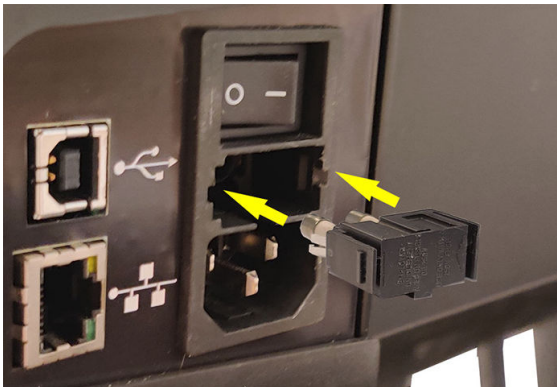

2. Remove the fuse holder.
3. Pull the fuse from the holder.
4. Put the new fuse in the holder and clip the holder back into place.

# Update the firmware

 **IMPORTANT:** Do not turn off the cutter during the firmware update process.

1. Ensure that you have HP Cutter Control installed. It is installed automatically during Print and Cut setup; if you have uninstalled it, you can download and reinstall it.
2. Run HP Cutter Control by double-clicking its icon.



HP Cutter Control

3. In HP Cutter Control, search for the cutter. The application searches the LAN by default; if that fails, you can connect by USB cable. The cutter details should appear in the Machine Info screen.

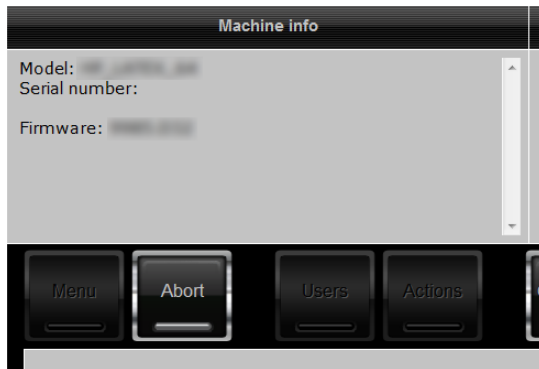

4. Click **Actions > Upgrade firmware**.

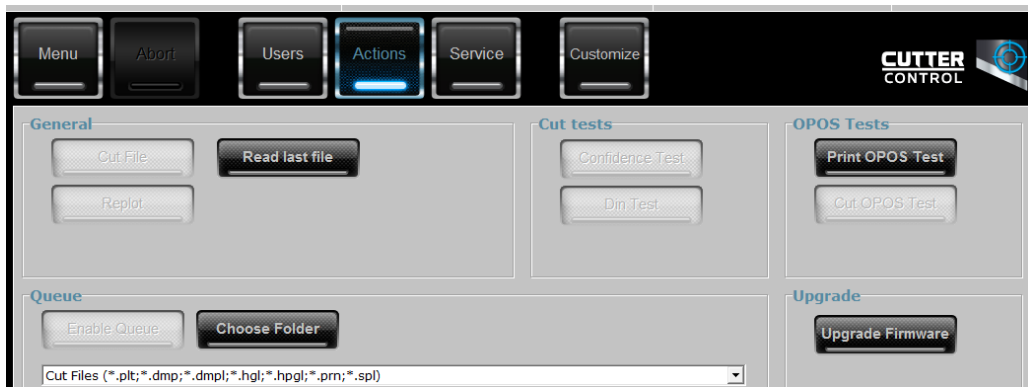

5. Download the firmware update file.
6. Restart the cutter.

You can alternatively download the latest firmware from <https://support.hp.com/us-en/drivers>.

---

# 7 Troubleshooting

## Cutting quality is not satisfactory

1. Perform the confidence test, and check whether quality issues are also visible in this internal test. If not, perhaps the problem is in the file.
2. Perform the knife pressure test, and replace knife if it is worn out. For regular vinyl, the knife pressure should be around 60–80 g for kiss cutting. When the knife starts to wear down, the pressure will increase.
3. Check that the knife is assembled correctly and doesn't stick out too much from its holder. The knife should protrude only slightly.
4. Check that the knife holder is assembled correctly, and pushed far enough into the head clamps. The distance between the bottom of the knife holder and the cutting strip should be close to 3 mm.
5. Check the knife offset value. Every knife has its own offset value. The offset is the distance from the knife tip to the center of the knife. When the offset is not set correctly, the corners of the cut job will be of low quality.
6. Check other parameters such as OptiCut, TurboCut, Overcut, and FlexCut, which could also influence the cutting quality.
7. Replace the knife.
8. Check the cutting strip. The cutting strip will also wear down, because the knife is always cutting in the same, central position of the cutting strip. A small dent is created in places on the cutting strip when the strip needs to be replaced.

## Substrate is drifting and you have tracking issues

1. Ensure that the substrate flanges are used with substrate rolls.
2. Ensure that the substrate flanges are both positioned on the substrate flange guides.
3. Ensure that the outside pinch rollers are always positioned 5 mm over the edge of the substrate.
4. Try reducing the cutting speed.

## Substrate jams

1. Try reducing the cutting pressure.
2. If you are using FlexCut, the parameters may not be set up correctly, so that the substrate starts to lose integrity or falls apart. Experiment with FlexCut parameters until you find ones that work.
3. You may be using FlexCut for shapes that are too complex. It should be used for simple shapes only.
4. Try reducing the cutting speed. If you cut too fast, the substrate may not have time to fold correctly in the basket.
5. Your jobs may be too long, causing problems in the basket. Try dividing jobs into shorter segments, such as one-meter panels.

## Cutter cannot detect HP barcode or registration marks

1. Ensure that you position the cutting head correctly when the cutter prompts you to do so. Carefully read the instructions on the cutter's screen when starting a cutting job.
2. This problem most often occurs with substrates that are colored or have certain laminations. Remember to calibrate the substrate before using it. See [Calibrate the substrate on page 17](#).
3. Check whether the sensor touches the substrate during barcode and marker detection.

See also [Calibrate the OPOS on page 37](#).

## Cutter can't detect that media is loaded or loading doesn't start after lowering the pinchwheels

### Media sensor sensitivity calibration

Depending on the color of the backing of the media loaded in the machine, the sensitivity of the media sensor may be adjusted, to be able to detect the presence of the media.

The media sensitivity setting is stored per user configuration. It is best to choose a user configuration, then calibrate the media sensor for this kind of media.

To access the "Media sensor setup" menu to adjust the media sensor sensitivity, follow these steps:

1. Start the machine.

2. Click the **Menu** button .



3. Scroll through the menu and click on **Calibrations**.
4. Select the option **Media sensor setup**.
5. Select the option **Measure**. A dialog will appear instructing to insert the media half on the sensor.

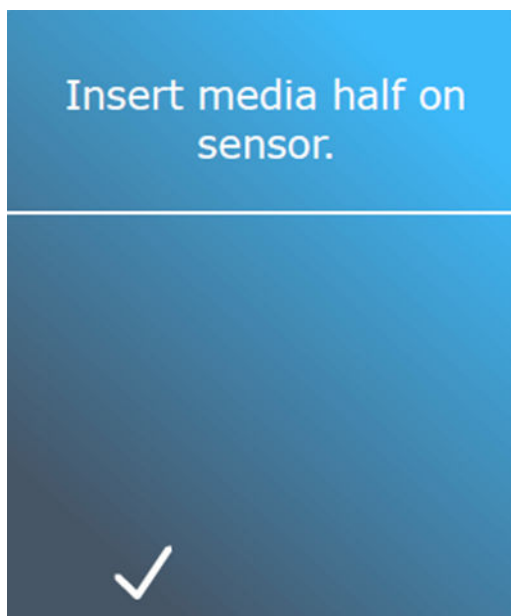

6. Load a piece of media from the front of the machine halfway on the sensor and under the two outermost pinch rollers.

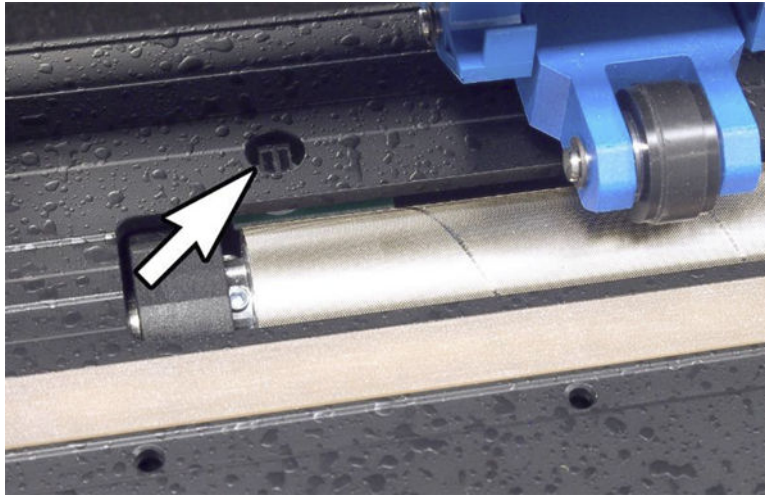

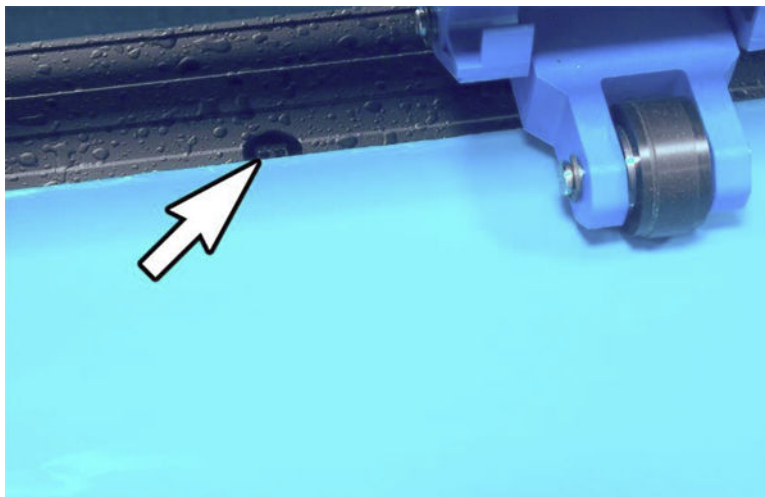

7. Lower the pinch rollers (pinch rollers need to be positioned over the grid rollers).

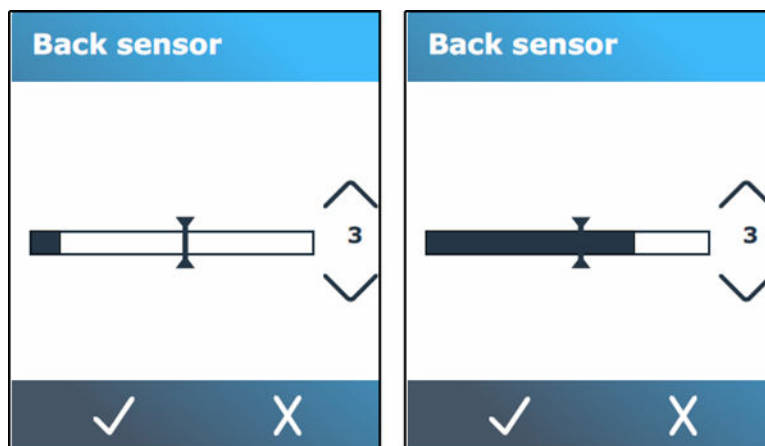

8. Press the **tick** button  to continue. The cutter moves the media backward and forward to cover and uncover the media sensor. The display alternatively shows the reflection value of the sensor when covered or not covered.



9. Use the **down** button  or the **up** button  to change the sensitivity. The sensitivity can be changed from 0 (high sensitivity) to 4 (low sensitivity). The sensitivity is correctly set when, if the sensor is covered, the bar graph is almost completely filled. When the sensor is uncovered, then the meter is (almost) empty.

 **NOTE:** The default value for the sensitivity is 3.

---

10. Move the **bar** slider  to set the trigger level. Ideally, the trigger level is set halfway along the bar graph when the sensor was covered and when the sensor was uncovered.

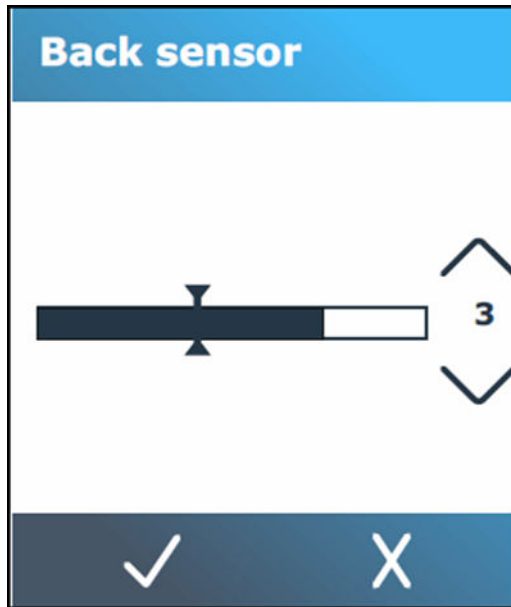

11. Press the **tick** button  to confirm the calibration.



## Media sensor activity

Alternatively, it is also possible to switch the media sensor off. The machine then assumes media is present, and will not check for the rear edge of the media. Switching the media sensor off may increase the risk of cutting in the cutting strip as the media may be fed out of the machine.

1. Power on the cutter.

2. Click the **Menu** button

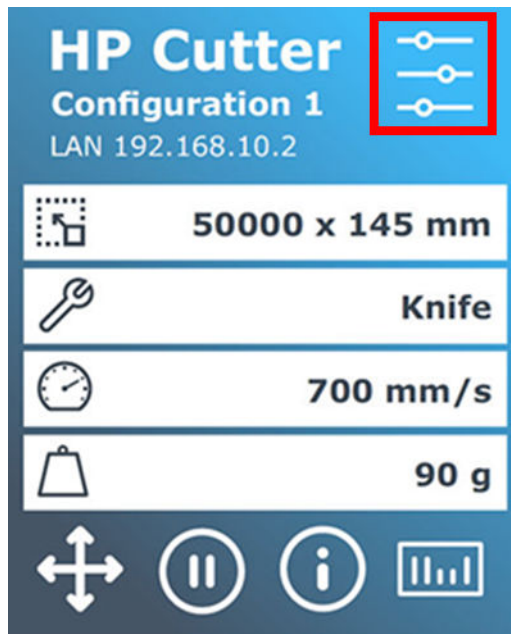

3. Scroll through the menu and click on **Configuration**.
4. Scroll through the menu and click on **Media sensor**.
5. Click on **Off** and confirm.

After disabling the media sensor, the loading procedure starts immediately after lowering the pinchwheels. The cutter advances the media a preset distance during the loading process. This preload length is equal to the media width plus 200 mm (with a maximum of 750 mm).

---

## 8 Accessories

There are two alternative ways to order supplies or accessories:

- Visit <http://www.hp.com/> on the Web. There you will also see the latest list of supplies and accessories for your cutter.
- Contact HP Support (see [When you need help on page 10](#)), and check that what you want is available in your area.

The rest of this chapter lists the available supplies and accessories, and their part numbers, at the time of writing.

### Order accessories

The following accessories can be ordered for your cutter.

#### Accessories

| Name                         | Part number |
|------------------------------|-------------|
| HP Latex Standard Blade Kit  | 1UP44A      |
| HP Latex Specialty Blade Kit | 1UP45A      |

#### HP Latex Standard Blade Kit

HP Latex Standard Blades are used to cut most common print-and-cut substrates, such as self-adhesive vinyl. This kit contains five blades and a cutting strip.

#### HP Latex Specialty Blade Kit

HP Latex Specialty Blades are used to cut some transfer substrates, and are also useful to produce rhinestone applications. This kit contains five blades and a cutting strip.

# 9 Specifications

## Cutter dimensions

|        | 54 basic plus cutter |  | 64 plus cutter    |
|--------|----------------------|--|-------------------|
|        | 54 plus cutter       |  |                   |
| Height | 1145 mm (45.1 in)    |  | 1145 mm (45.1 in) |
| Width  | 1750 mm (68.9 in)    |  | 1980 mm (77.9 in) |
| Depth  | 680 mm (26.8 in)     |  | 680 mm (26.8 in)  |
| Weight | 42 kg (92 lb)        |  | 54 kg (119 lb)    |

## Shipping dimensions

|        | 54 basic plus cutter |  | 64 plus cutter    |
|--------|----------------------|--|-------------------|
|        | 54 plus cutter       |  |                   |
| Height | 670 mm (26.4 in)     |  | 670 mm (26.4 in)  |
| Width  | 1880 mm (74.0 in)    |  | 2110 mm (83.1 in) |
| Depth  | 480 mm (18.9 in)     |  | 480 mm (18.9 in)  |
| Weight | 69 kg (152 lb)       |  | 78 kg (172 lb)    |

## Substrate dimensions

|                                   | 54 basic plus cutter | 54 plus cutter    | 64 plus cutter    |
|-----------------------------------|----------------------|-------------------|-------------------|
| Minimum width                     | 280 mm (11.0 in)     | 180 mm (7.1 in)   | 180 mm (7.1 in)   |
| Maximum width                     | 1372 mm (54.0 in)    | 1410 mm (55.5 in) | 1635 mm (64.4 in) |
| Pinch rollers                     | 3                    | 4                 | 4                 |
| Maximum working width             | –                    | 1350 mm (53.1 in) | 1575 mm (52.1 in) |
| Maximum working width (oversized) | –                    | 1380 mm (54.3 in) | 1605 mm (63.2 in) |

| 54 basic plus cutter               |                |
|------------------------------------|----------------|
| 54 and 64 plus cutters             |                |
| Maximum working length             | 50 m (164 ft)  |
| Front and rear margins             | 30 mm (1.2 in) |
| Side margins                       | 25 mm (1.0 in) |
| Margin between prints (no cut-off) | 30 mm (1.2 in) |
| Margin to cut off                  | 30 mm (1.2 in) |

| 54 basic plus cutter, 54 and 64 plus cutters |   |
|--|---|
| Tracking performance                         | Up to 8 m (26 ft) within guaranteed specifications for substrates less than 762 mm (30 in) wide<br>Up to 4 m (13 ft) within guaranteed specifications for substrates more than 762 mm (30 in) wide<br>Longer substrates can be handled, but then compliance with specifications is not guaranteed |
| Thickness                                    | 0.05 to 0.25 mm (0.002 to 0.01 in) with standard knife<br>Up to 0.8 mm (0.03 in) with optional sandblast knife  |

 **NOTE:** Tracking performance is not guaranteed in oversized mode.

## Performance

This performance is achieved with wax-backed vinyl 0.05 mm (0.002 in) thick, total thickness not more than 0.25 mm (0.01 in).

|               |   |
|---------------|---|
| Cut type      | Drag-knife with TurboCut and Tangential emulation modes   |
| Cut width     | 135 cm (53.1 in) for the HP Latex 64 Cutter<br>158 cm (62.2 in) for the HP Latex 54 Cutter            |
| Cut speed     | Up to 113 cm/s (44 in/s) diagonal<br>Up to 84 cm/s (33 in/s) for substrates wider than 736 mm (29 in) |
| Acceleration  | Up to 3 G diagonal<br>Up to 0.9 G for substrates wider than 736 mm (29 in)                            |
| Accuracy      | 0.2% of movement or 0.25 mm (0.01 in), whichever is greater   |
| Repeatability | ±0.1 mm (0.004 in)  |
| Cut force     | 0 to 400 g of downforce, in 5 g steps   |
| Cut thickness | 0.05 to 0.25 mm (0.002 to 0.01 in)<br>0.8 mm (0.03 in) with optional sandblast blade                  |

 **NOTE:** The repeatability and accuracy specifications are valid within the guaranteed tracking length (see previous table), but not in oversized mode.

## Firmware

|                          |  |
|--------------------------|--|
| Language                 | DM/PL, HP-GL (758x emulation), HP-GL/2 |
| Supported character sets | Standard ASCII                         |
| Supported fonts          | Sans serif (single stroke and medium)  |
| ROM-based plots          | Confidence plot, DIN plot              |

## Environment

These specifications are for the cutter without substrate.

|                       |                            |
|-----------------------|----------------------------|
| Operating temperature | 15 to 35°C (59 to 95°F)    |
| Storage temperature   | -30 to 70°C (-22 to 158°F) |
| Relative humidity     | 35 to 75%, non-condensing  |

 **TIP:** The use of dimensionally stable substrate is an essential pre-requisite to obtain high cut quality. Additionally, substrate expansion or contraction may occur as a result of temperature variations. To improve the dimensional stability of substrate, let it stabilize to the current environmental conditions before use, for a minimum period of 24 hours.

## Electrical

The power entry module detects the line voltage and switches automatically between 100 V and 240 V.

|                      |            |
|----------------------|------------|
| Input voltage        | 100–240 V  |
| Input frequency      | 50/60 Hz   |
| Maximum load current | 2 A        |
| Power consumption    | 85 VA      |
| Fuses                | T2.0A 250V |

 **WARNING!** For continued protection against risk of fire, replace fuses only with the same type and rating of fuse.

## Acoustic

These are the declared noise emission levels for your cutter. Sound pressure is measured at bystander positions, and sound power level is measured according to ISO 7779.

|                                | 140D       | 160D       |
|--------------------------------|------------|------------|
| Idle sound pressure level      | 26 dB(A)   | 26 dB(A)   |
| Idle sound power level         | ≤ 4.3 B(A) | ≤ 4.3 B(A) |
| Operating sound pressure level | 55 dB(A)   | 56 dB(A)   |
| Operating sound power level    | ≤ 7.1 B(A) | ≤ 7.3 B(A) |

---

# Index

- A**
  - accessories 62
- C**
  - calibrate
    - OPOS 37
    - substrate 17
  - caution 5
  - clean cutter surfaces 50
  - clean drive system 50
  - clean substrate sensor 51
  - clean Y-guide rail 51
  - components of cutter 6
  - connection to a computer 8
  - Customer Care 10
  - Customer Self Repair 11
  - cut through 27
  - cut types 27
  - cutter models 2
  - cutter on/off 8
  - cutter's main components 6
  - cutter's main features 2
  - cutting automation 33
  - cutting workflow 27
- D**
  - direct cut 27
  - documentation 2
- E**
  - Ethernet connection 8
- F**
  - firmware update 55
  - FlexCut parameters 29
  - front panel 9
    - main menu 42
  - front view 6
  - fuse, change 54
- H**
  - HP barcode, read 36
  - HP Customer Care 10
- J**
  - job
    - direct cut 27
    - print and cut 27
  - job editing 30
  - job management 30
  - job types 27
- K**
  - kiss cut 27
  - knife depth 19
  - knife pressure 19
  - knife replacement 52
- L**
  - labels, warning 5
  - LAN connection 8
  - length calibration 21
  - links 10
- M**
  - manuals 2
- O**
  - offset 53
  - on/off 8
  - OPOS
    - calibrate 37
    - OPOS origin 35
    - origin
      - change 38
- P**
  - pinch rollers
    - position 16
  - power on/off 8
  - pressure 19
  - print and cut 27
- R**
  - rear view 7
- S**
  - safety labels 5
  - safety precautions 3
  - specifications 63
  - speed 20
  - substrate
    - calibrate 17
    - cut 27
    - load 12
  - support services
    - HP Customer Care 10
- T**
  - telephone number 10
  - telephone support 10
  - troubleshooting 56
- U**
  - USB connection 8
  - user
    - change 25
- V**
  - velocity 20
- W**
  - warning 5
  - warning labels 5
  - welcome to your cutter 2